

# SECTOR II TRAFFIC BARRIER INSTALLATION MANUAL



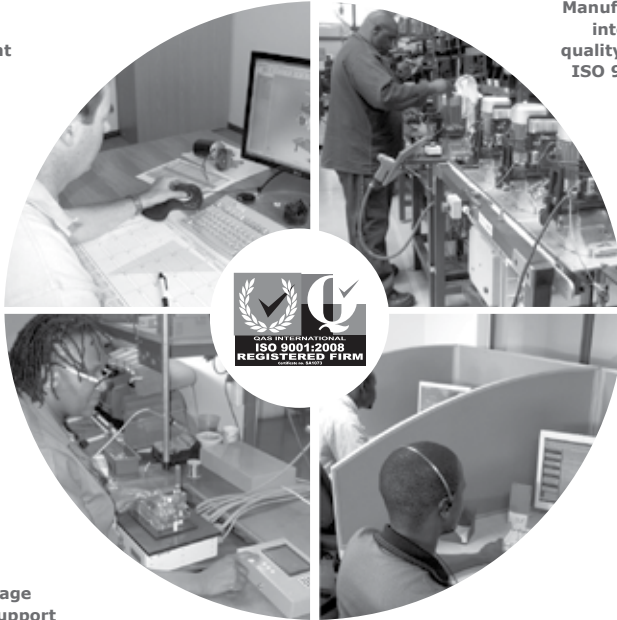
# SECTOR II



# Company Profile



**In-house  
R&D  
development  
team**



**Manufactures to  
international  
quality standard  
ISO 9001:2015**

**After-sales  
multi-language  
Technical Support**

**100%  
testing of  
products**



**Sales and technical support  
to Africa, Europe, Asia,  
the Americas, Australia  
and the Pacific**

## **Call Centre Operating Times**

**Monday to Friday**  
08h00 to 17h00 GMT+2,

**Saturdays**  
08h00 to 14h00 GMT+2

**Centurion Systems (Pty) Ltd** reserves the right to make changes to the products described in this manual without notice and without obligation to notify any persons of any such revisions or changes. Additionally, **Centurion Systems (Pty) Ltd** makes no representations or warranties with respect to this manual. No part of this document may be copied, stored in a retrieval system or transmitted in any form or by any means electronic, mechanical, optical or photographic, without the express prior written consent of **Centurion Systems (Pty) Ltd**.



# Contents



## IMPORTANT SAFETY INSTRUCTIONS

page 5

<b>1. Glossary of terms</b>	page 7
<b>2. Product identification</b>	page 8
2.1 Internal components	page 8
2.2 External components	page 9
2.3 Electronics tray	page 9
2.4 Hardware unpacking	page 10
<b>3. Physical installation</b>	page 11
3.1 Orientation of the <b>SECTOR II</b>	page 11
3.2 Preparation of the cabinet plinth	page 12
3.3 Mounting the cabinet	page 13
3.4 Fitting and levelling the boom pole	page 14
<b>4. Onsite electrical wiring</b>	page 17
4.1 AC and DC power isolation	page 18
4.2 Earthing the unit	page 18
4.3 Wiring AC power to the <b>SECTOR II</b> Traffic Barrier	page 18
4.4 Installing loop detectors	page 19
4.4.1 Installing a single FLUX SA loop detector	page 19
4.4.2 Installing dual FLUX SA loop detectors	page 21
<b>5. Basic controller setup</b>	page 23
5.1 Powering up the <b>SECTOR II</b>	page 23
5.2 Programming the controller	page 23
<b>6. Installation handover</b>	page 27
<b>7. Advanced controller setup</b>	page 29
7.1 Menu navigation map	page 29
<b>Installation flow diagram: Center-fold pull-out</b>	page 39
<b>8. Maintenance</b>	page 47
8.1 How and when to do maintenance	page 47
8.2 Site related issues	page 49

8.3	Basic adjustments	page 50
8.4	Basic checks for the CLAWS Roadway Spikes	page 50
<b>9.</b>	<b>Troubleshooting</b>	page 51
9.1	Diagnostics	page 51
<b>10.</b>	<b>Appendices</b>	page 54
10.1	<b>SECTOR II</b> specifications	page 54
	10.1.1 Unit specifications	page 54
	10.1.2 Barrier boom pole specifications	page 55
	10.1.3 Fuse protection	page 55
	10.1.4 Certificate of compliance	page 56
10.2.	Changing the <b>SECTOR II</b> to a left-hand configuration	page 57
10.3	Adjusting limits for Fail-safe Mode	page 63
10.4	11-pin loop detector installations	page 64
	10.4.1 Installing a single FLUX 11-pin loop detector	page 66
	10.4.2 Installing dual FLUX 11-pin loop detectors	page 68
10.5	Safety beam installation	page 70
10.6	Wiring diagrams for installation modes	page 71
	10.6.1 Simplex Mode	page 71
	10.6.2 Complex Mode (Option 1)	page 72
	10.6.3 Complex Mode (Option 2 - Ticket vendors)	page 73
	10.6.4 Uni-directional traffic	page 74
	10.6.5 Bi-directional traffic	page 74
10.7	Factory Default Settings (South Africa only)	page 75
10.8	Terminal descriptions	page 77
10.9	Ancillary installation equipment	page 79

### Icons used in this manual



This icon indicates tips and other information that could be useful during the installation.



This icon denotes variations and other aspects that should be considered during installation.



**This icon indicates warning, caution or attention! Please take special note of critical aspects that MUST be adhered to in order to prevent injury.**



**This icon indicates areas where mechanical crushing may occur.**

# IMPORTANT SAFETY INSTRUCTIONS

## ATTENTION

To ensure the safety of people and possessions, it is important that you read all the following instructions.

Incorrect installation or incorrect use of the product may cause serious harm to people and / or property.

The installer is the last person on the site who can ensure that the operator is safely installed, and that the whole system can be operated safely.



## Warnings for the installer

**CAREFULLY READ AND FOLLOW ALL INSTRUCTIONS before beginning to install the product.**

This product is an automated mechanical and electrical system and must be installed, adjusted, and serviced by a competent person, as defined in applicable South African occupational health and safety legislation. Electrical connections must comply with SANS 10142-1 and the Electrical Installation Regulations. Installation requirements are aligned with applicable SANS IEC 60335 safety standards for automated doors and gates. Failure to comply may result in injury, death, property damage, and voiding of warranty.

- All installation, repair, and service work to this product must be carried out by a suitably qualified person
- Do not activate your barrier unless you can see it and can determine that its area of travel is clear of people, pets, or other obstructions
- **NO ONE MAY CROSS THE PATH OF A MOVING BARRIER.** Always keep people and objects away from the barrier and its area of travel
- **NEVER LET CHILDREN OPERATE OR PLAY WITH THE BARRIER CONTROLS**
- Secure all easily-accessed barrier controls in order to prevent unauthorised use of the barrier
- Do not in any way modify the components of the automated system
- Do not install the equipment in an explosive atmosphere: the presence of flammable gasses or fumes is a serious danger to safety
- Before attempting any work on the system, cut electrical power to the operator and disconnect the batteries
- The mains power supply of the automated system must be fitted with an all-pole switch with contact opening distance of 3mm or greater. Use of a 5A thermal breaker with all-pole circuit break is recommended

- Make sure that an earth leakage circuit breaker with a threshold of 30mA is fitted upstream of the system
- Never short-circuit the battery and do not try to recharge the batteries with power supply units other than that supplied with the product, or manufactured by Centurion Systems (Pty) Ltd
- Make sure that the earthing system is correctly constructed, and that all metal parts of the system are suitably earthed
- Safety devices must be fitted to the installation to guard against mechanical movement risks, such as crushing, dragging and shearing
- It is recommended that at least one warning indicator light be fitted to every system
- Always fit the warning signs visibly to the inside and outside of the barrier
- The installer must explain and demonstrate the manual operation of the barrier in case of an emergency, and must hand over the user guide to the user
- Explain these safety instructions to all persons authorised to use this barrier, and be sure that they understand the hazards associated with traffic barriers
- Do not leave packing materials (plastic, polystyrene, etc.) within reach of children as such materials are potential sources of danger
- Dispose of all waste products like packing materials, worn-out batteries, etc. according to local regulations
- Always check the obstruction detection system and safety devices for correct operation
- Neither Centurion Systems (Pty) Ltd, nor its subsidiaries, accepts any liability caused by improper use of the product, or for use other than that for which the automated system was intended
- This product was designed and built strictly for the use indicated in this documentation. Any other use, not expressly indicated here, could compromise the service life/operation of the product and/or be a source of danger
- Anything that has not been specified in these instructions may be considered a risk to your safety, and the safety of others. If you are unsure of an installation matter, please contact your nearest distributor



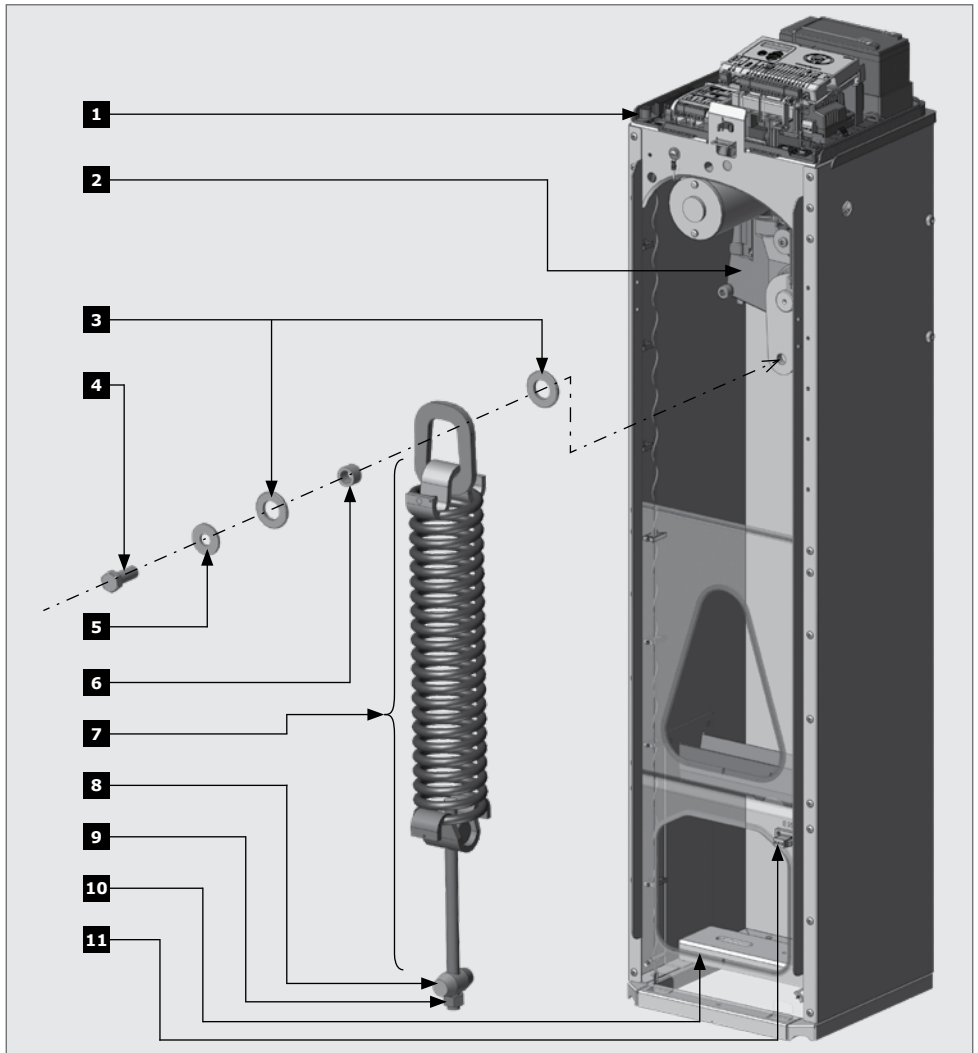
# 1. Glossary of Terms

<b>SECTOR II</b>	3, 4.5 or 6m traffic barrier manufactured by Centurion Systems (Pty) Ltd
<b>Boom</b>	Aluminium pole used to close off roadway or section thereof
<b>Loop</b>	Inductive loop manufactured to sense a vehicle when it passes over the loop. Minimum 2.5m wide by 1m
<b>Counterbalance assembly</b>	A spring-assembly to balance the boom pole
<b>Hold down bracket</b>	Bracket used to clamp the cabinet in position
<b>CP84 SM 2A Charger</b>	Battery charger
<b>Camlock</b>	Cabinet-type lock, (60198 Keyed-alike)
<b>DIP switch</b>	Selectable binary switches (two-position)
<b>Modes of Operation</b>	Selection that dictates how the <b>SECTOR II</b> barrier will react to external stimuli
<b>Duty cycle</b>	Percentage per unit time within which the barrier can operate, i.e. 48 minutes in an hour
<b>Collision-sensing operation</b>	The ability of the boom to detect an obstruction and reverse direction
<b>Manual Operation</b>	Allows emergency manual operation of boom without utilising the manual-override

**TABLE 1**

## 2. Product Identification

### 2.1. Internal Components



**FIGURE 1. PRODUCT IDENTIFICATION - INTERNAL COMPONENTS**

- |                                       |                             |
|---------------------------------------|-----------------------------|
| 1. Electronics tray                   | 7. Counterbalance assembly  |
| 2. Gearbox assembly (3m, 4,5m and 6m) | 8. Taper roller             |
| 3. Spring assembly locating washer    | 9. Tension-bar nut          |
| 4. Spring assembly bolt               | 10. Hold down bracket       |
| 5. Spring-washer                      | 11. AC Mains terminal block |
| 6. Spring assembly bush               |                             |

## 2.2. External components

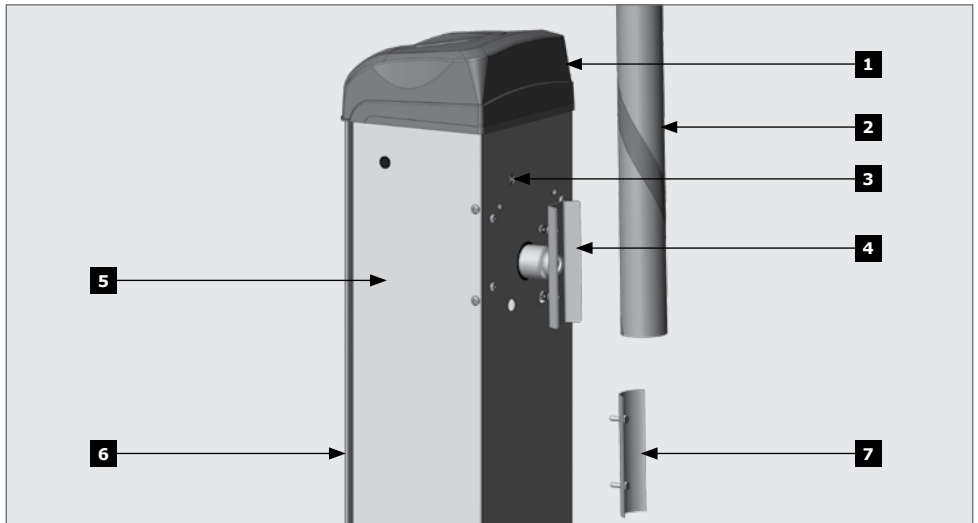


FIGURE 2. PRODUCT IDENTIFICATION - EXTERNAL COMPONENTS

- |  |                       |
|--|-----------------------|
| 1. Barrier lid                                   | 4. Boom pole coupler  |
| 2. Boom pole (3m, 4.5m and 6m)<br>(not supplied) | 5. Barrier enclosure  |
| 3. Manual override (6mm Allen key)               | 6. Door               |
|  | 7. Boom pole retainer |

## 2.3. Electronics tray

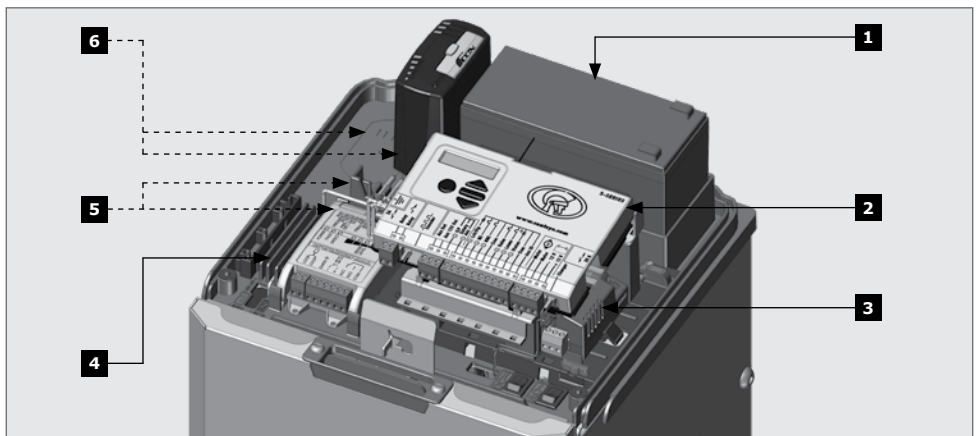
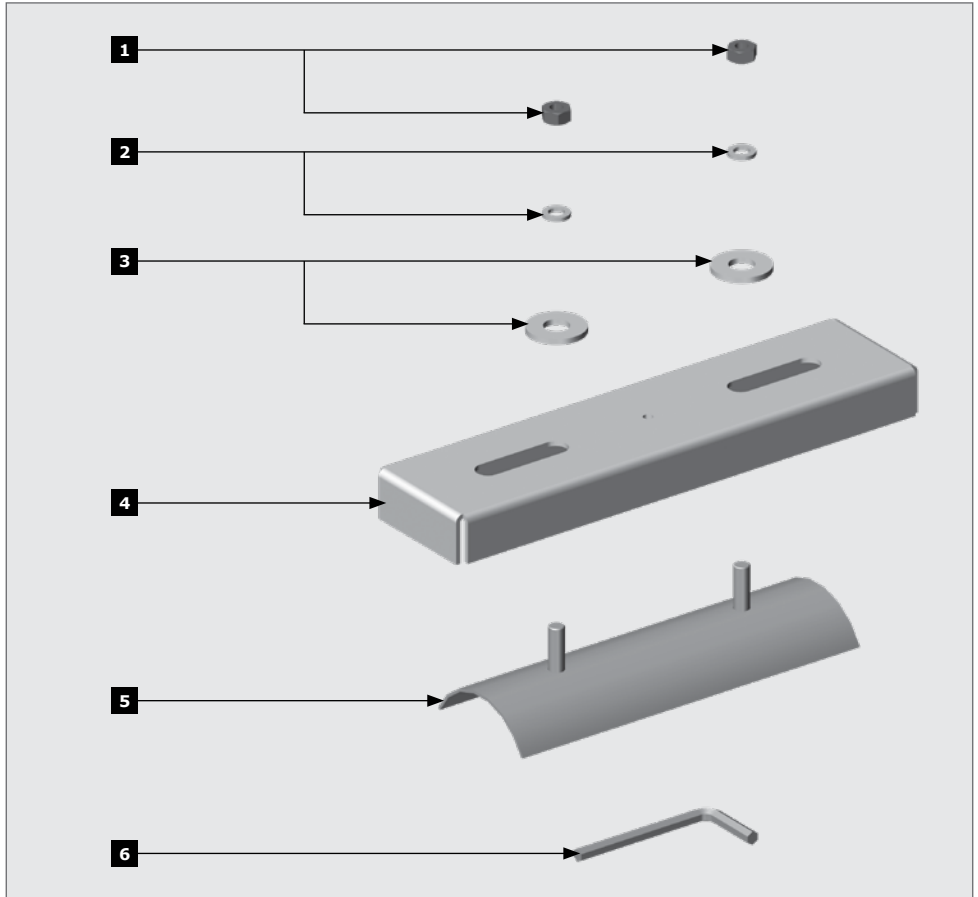


FIGURE 3. PRODUCT IDENTIFICATION - ELECTRONICS TRAY

- |                       |   |
|-----------------------|---|
| 1. CP4 7Ah battery    | 5. FLUX SA loop detector – single ( <b>optional</b> )<br>FLUX SA loop detector – double ( <b>optional</b> )         |
| 2. Barrier controller | 6. FLUX 11-Pin loop detector – single ( <b>optional</b> )<br>FLUX 11-Pin loop detector – double ( <b>optional</b> ) |
| 3. CP84 SM 2A charger |   |
| 4. Wiring channels    |   |

## 2.4. Hardware unpacking

When unpacking the **SECTOR II**, necessary hardware can be found attached to the enclosure. The hardware is as follows:



**FIGURE 4. PRODUCT IDENTIFICATION - HARDWARE**

- |  |  |
|--|--|
| 1. M8 Nuts<br>(for boom pole retainer)                   | 4. Hold down bracket                   |
| 2. M8 Spring Washers<br>(for boom pole retainer)         | 5. Boom pole retainer                  |
| 3. M12 Heavy duty washers<br>(for the Hold Down Bracket) | 6. 6mm Allen key (for manual override) |

## 3. Physical Installation

### 3.1. Orientation of the SECTOR II

The **SECTOR II** can be installed in different configurations. It is important to fully understand the site requirements before purchasing the unit. The following steps detail the differences between the orientations:

#### Step 1

Look at the site and decide where the unit will be positioned.

#### Step 2

Determine which direction the pole will face. This will enable you to ascertain whether a right-hand or left-hand barrier is needed for the installation.

Left-Hand Barrier	Right-Hand Barrier
<ul style="list-style-type: none"> <li>A left-hand barrier is a unit that is installed on the left-hand-side of the road from which the vehicle approaches. The door always faces the approaching vehicle</li> <li>If a left-hand unit is required, it may be necessary to convert the barrier to a left-hand barrier(see next point)</li> <li>A left-hand configured <b>SECTOR II</b> is available from Centurion Systems (Pty) Ltd upon request. Please note that left-hand configurations may require longer lead times</li> </ul>	<ul style="list-style-type: none"> <li>A right-hand barrier is a unit that is installed on the right-hand-side of the road from which the vehicle approaches. The door always faces the approaching vehicle</li> <li>All units are manufactured as right-hand units, unless otherwise specified</li> <li>It is always recommended to mount the barrier with the access-door facing the oncoming traffic. This ensures that if a vehicle hits the pole, the pole is knocked away from the barrier housing</li> </ul>

TABLE 2

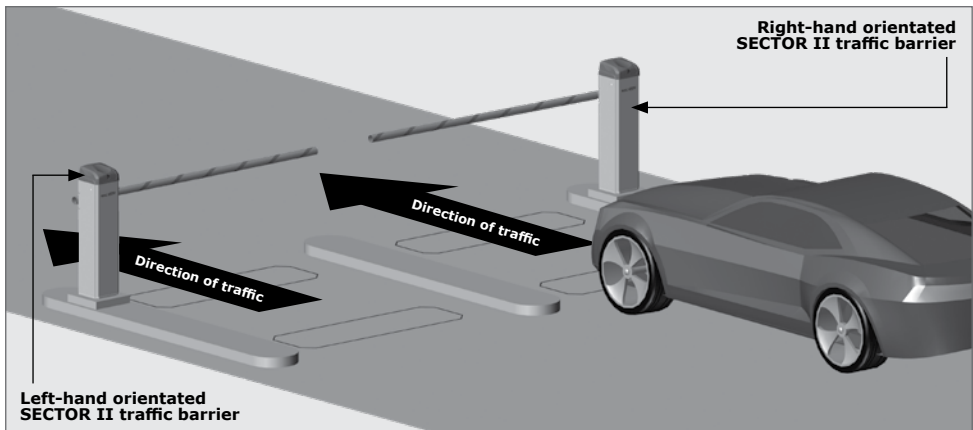



FIGURE 5

## 3.2. Preparation of the Cabinet Plinth


It is assumed that all details discussed in the document “**SECTOR II** pre-installation buyers' guide” are complete and physical installation of the system onsite is about to start.

If Section 5 of the Pre-installation Buyers' guide has not been followed, for convenience we have repeated what is requires to prepare the plinth before mounting the cabinet.

 Install an earth-spike and hold down studs (if not using rawl bolts), as shown in Figure 5 and Figure 6 before casting the plinth.

### Step 6

Using medium strength concrete (25Mpa), cast the plinth with dimensions as shown in Figure 6 and Figure 7. Allow to dry.

 Ensure that 30mm of conduit protrudes above the concrete, and that the mains wires will emerge within the cabinet at least 400mm in length.

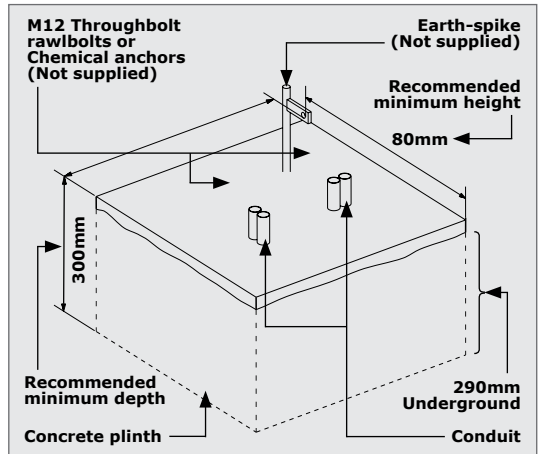



FIGURE 6. PLINTH DIMENSIONS

 Should a 33Ah battery need to be installed, the studs need to be cut to length subsequent to the **SECTOR II** being secured to the plinth.

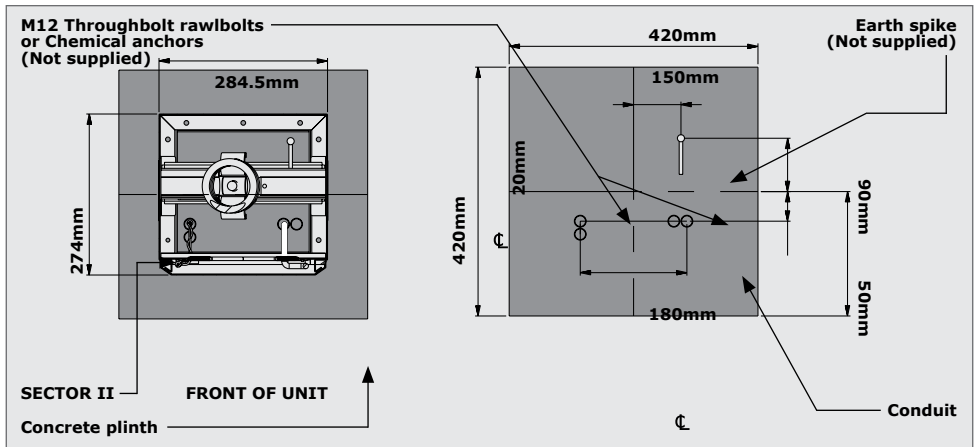


FIGURE 7

### 3.3. Mount the cabinet

#### Step 1

Remove the lid **before** removing the door.



**The lid is not attached to the barrier enclosure. Hold the lid securely while pivoting it up, and removing the lid.**

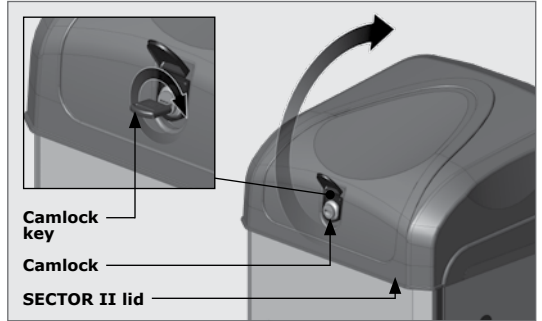


FIGURE 8



The Controller, Battery, Charger Unit, and Loop Detectors are all accessible once the lid of the **SECTOR II** has been removed.

#### Step 2

Pull the door release to open the door (1). The door is then removed by lifting it up and away (2).

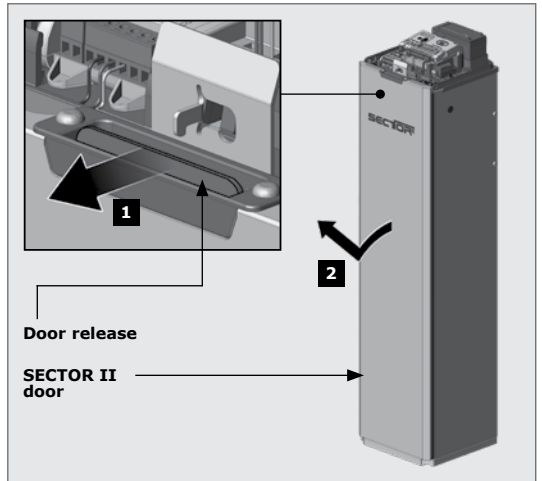


FIGURE 9

#### Step 3

Position the unit on the pre-installed plinth.

#### Step 4

Ensure that the unit is level and that the conduit and cables have suitable clearance from moving parts.

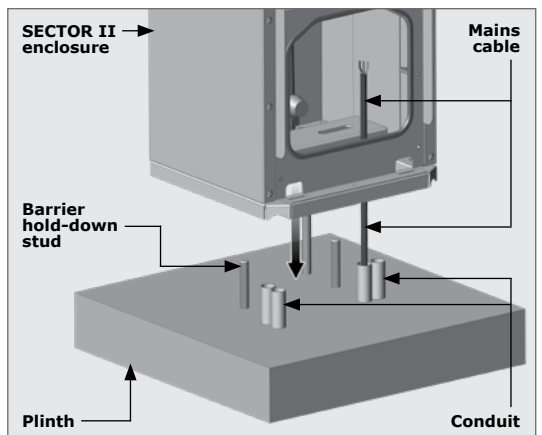


FIGURE 10

**Step 5**

Ensure the hold-down bracket is the right way up before securing it in position (Figure 11).

Bolt the hold-down bracket in position to clamp the barrier onto the plinth (Figure 12).

If there is a need to install the **SECTOR II** barrier in the left-hand configuration and it has not been pre-ordered, keep the barrier bolted in place. Refer to Appendix 2 - **Changing a unit to a left-hand configuration**

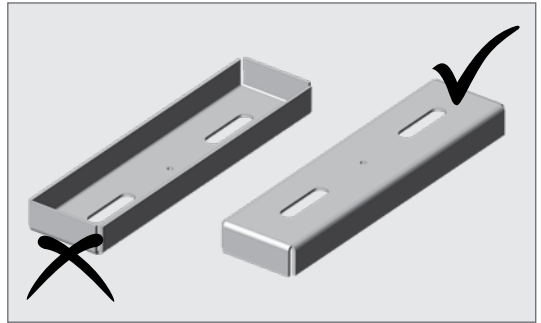


FIGURE 11

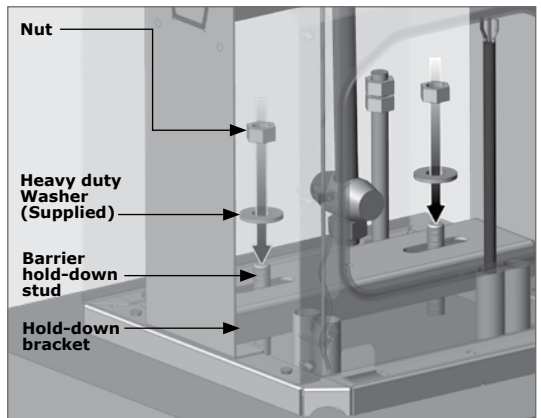


FIGURE 12

### 3.4. Fitting and levelling the boom pole

#### 3.4.1. Fitting the pole

**Step 1**

Carefully remove the end cap from one end of the boom pole.

**Step 2**

Use the retainer assembly to mark a line along the pole.

**Step 3**

From the edge of the pole, mark and centre punch the hole positions at 65mm and 175mm (Figure 13).

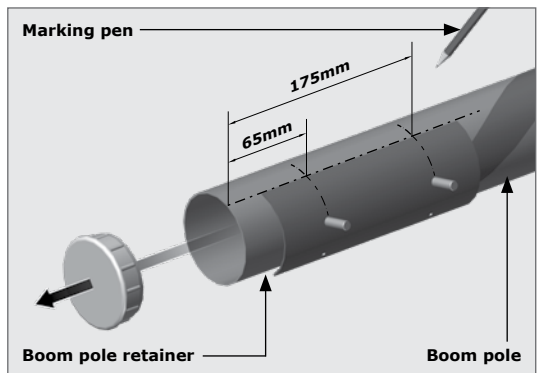


FIGURE 13

**Step 4**

Drill two 8.5mm holes.



**Holes must be drilled through only one wall of the boom pole.**

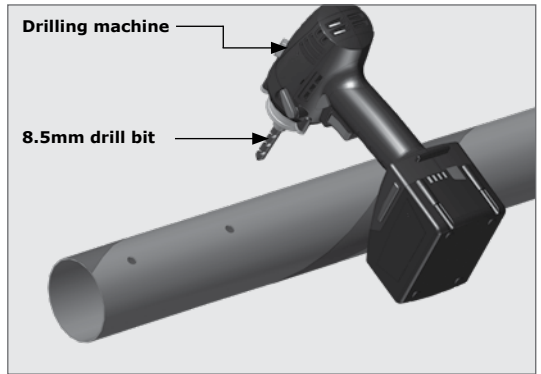


FIGURE 14

**Step 5**

Insert the boom pole retainer and locate the threaded studs in the drilled holes.

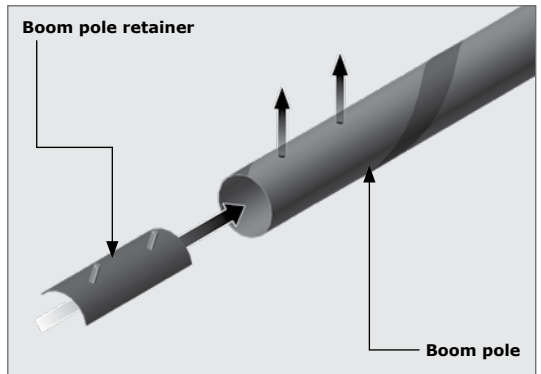


FIGURE 15

**Step 6**

Fasten the boom pole as shown and replace the end cap (Figure 16).

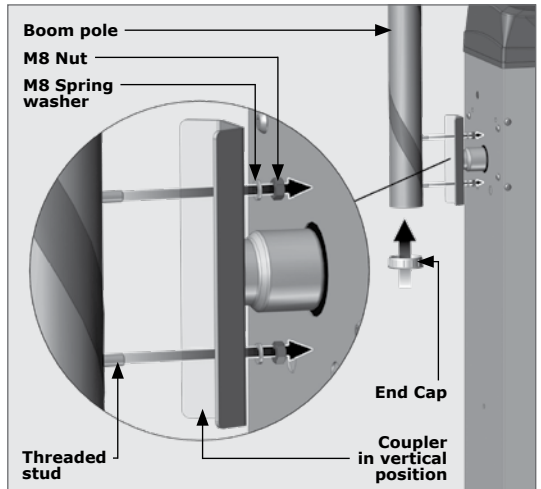


FIGURE 16

### 3.4.2. Leveling the boom pole



**Mechanical crushing may occur**

#### Step 1

Using the manual override, move the boom pole to the lowered position.

#### Step 2

If the pole is not horizontal, loosen both lock nuts on the adjustment link using 2x 17mm spanners (Figure 17).

#### Step 3

Adjust the adjustment link to achieve a level boom. Use a spirit level on the boom pole, then tighten the lock nuts using 2x 17mm spanners.

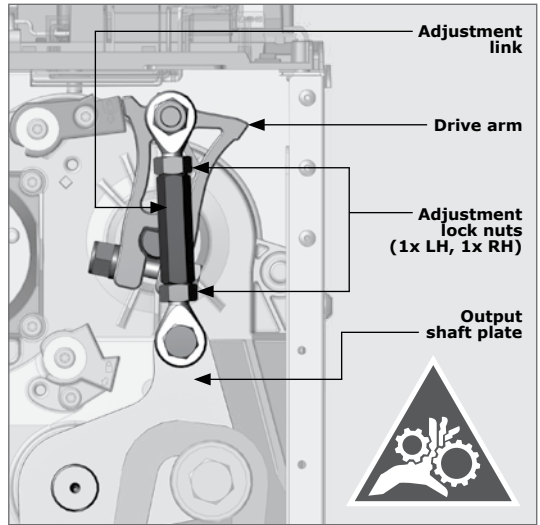


FIGURE 17



Figure 17 shows a right-hand configuration. Although the left-hand configuration looks different, the levelling procedure remains the same.

### 3.4.3. Coarse adjustment of the spring tension

The spring tension is adjusted at the factory. Should the spring tension need to be adjusted, follow the steps below.

#### Step 5

Manually override the boom pole so that it rests under the tension of the spring.

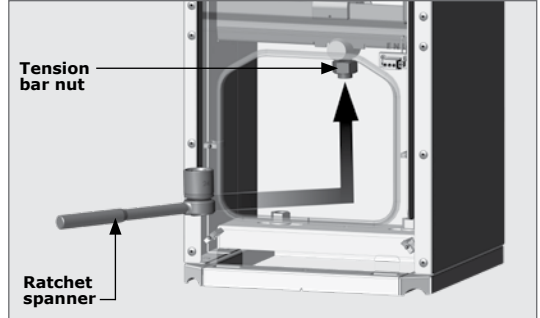


FIGURE 18

#### Step 6

Use a 24mm socket (4.5m and 6m boom) or a 17mm socket (3m boom) to adjust the spring so that the boom pole rests at an angle of approximately  $45^\circ$ . The optimal position will be determined by the electronics when the unit is set up.

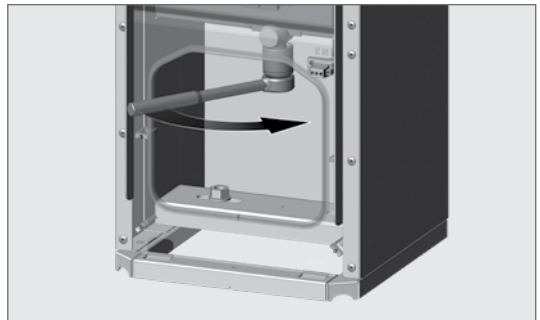


FIGURE 19

## 4. Onsite Electrical Wiring



Before commencing with wiring, ensure that all power to the **SECTOR II** is OFF.

### 4.1. AC and DC power isolation

#### Step 1

Switch off both the AC and DC isolators (Figure 20)

#### Step 2

Install and connect the 12V, 7.5Ah battery.

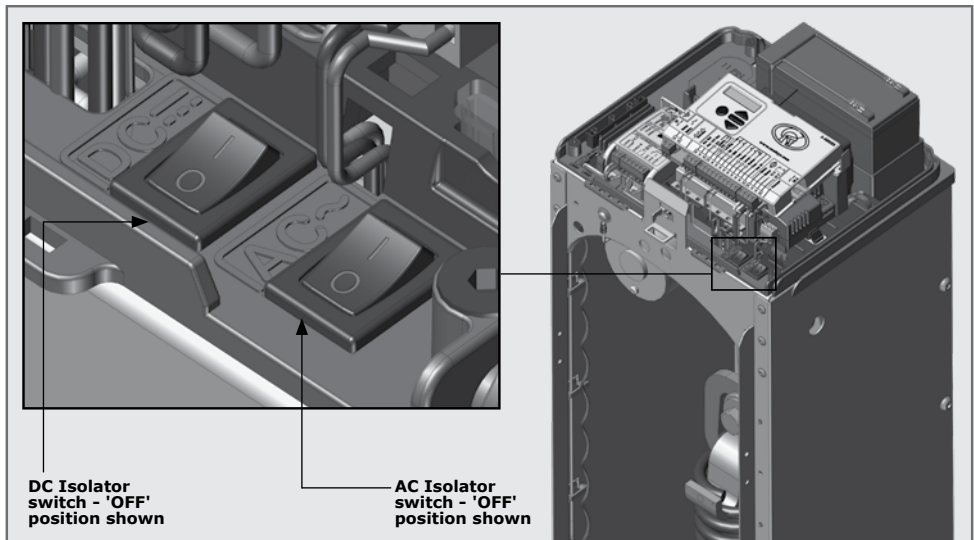


FIGURE 20

## Lightning Protection

The **S-SERIES** electronic controller utilises the same proven surge protection philosophy that is used in all products from Centurion Systems (Pty) Ltd. While this does not guarantee that the unit will not be damaged in the event of a lightning strike or power surge, it greatly reduces the likelihood of such damage occurring. The earth return for the surge protection is provided via the mains power supply earth.



In order to ensure that the surge protection is effective, it is essential that the unit is properly earthed.

## 4.2. Earthing the unit

Connect the earth spike (Figure 21) to the designated earth point (Figure 22) using 5mm<sup>2</sup> copper-weave conductor and the self-tapping screw provided.

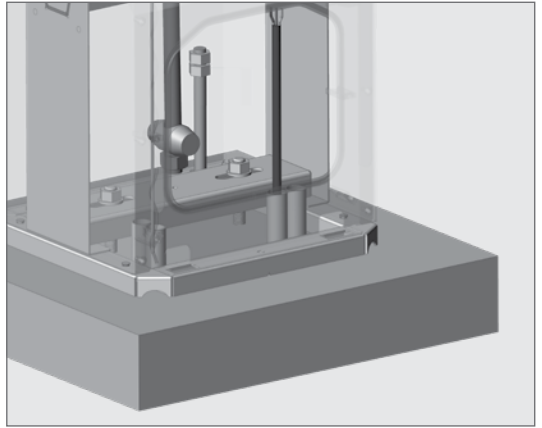


FIGURE 21

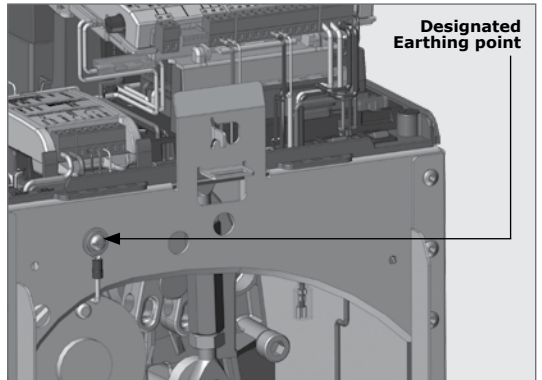


FIGURE 22

## 4.3. Wiring AC power to the SECTOR II traffic barrier

Route and connect the 220V AC Mains cable (Figure 23).

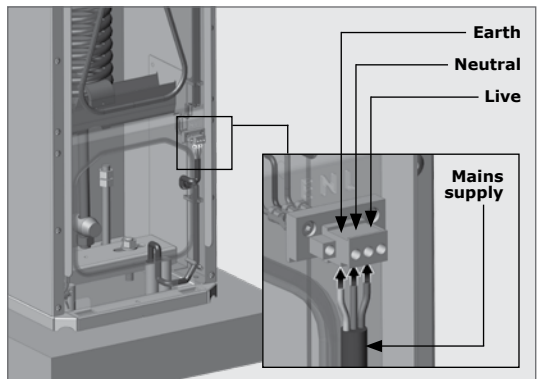


FIGURE 23

#### 4.4. Installing loop detectors

The **SECTOR II** can use various types of loop detector.

Centurion Systems (Pty) Ltd recommends using the FLUX SA (standalone) loop detector, as the unit is easily clipped into place and wired.

##### Loop detector variations:

- Single FLUX SA
- Dual FLUX SA
- Single FLUX 11-pin (Appendix 4)
- Dual FLUX 11-pin (Appendix 4)

##### 4.4.1. Installing a single FLUX SA loop detector

###### Step 1

Clip the FLUX SA into the electronics tray.

###### Step 2

Wire the FLUX SA to the controller using the supplied harness as per the wiring diagram (Figure 27).

###### Step 3

Run the TWISTED loop wires up inside the enclosure through the wiring clips to the FLUX SA (Figure 26). Connect the twisted loop wires to the FLUX SA.

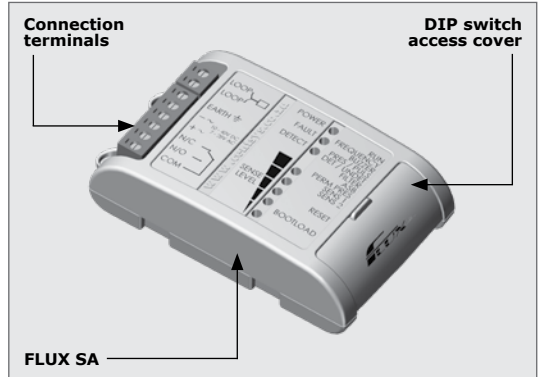


FIGURE 24

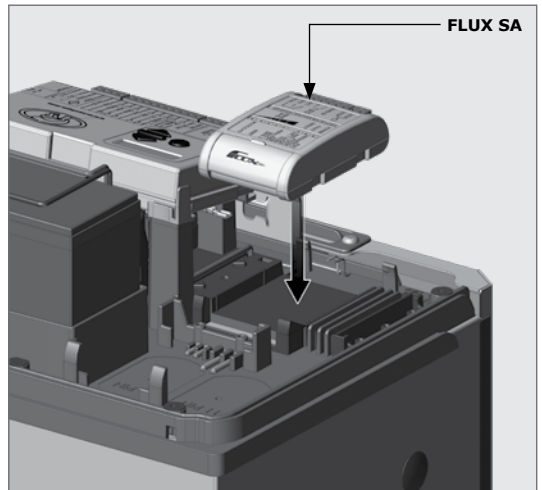


FIGURE 25

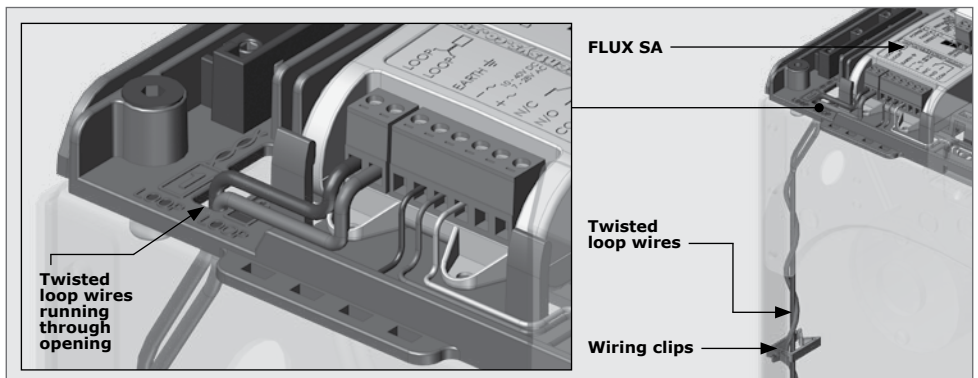


FIGURE 26

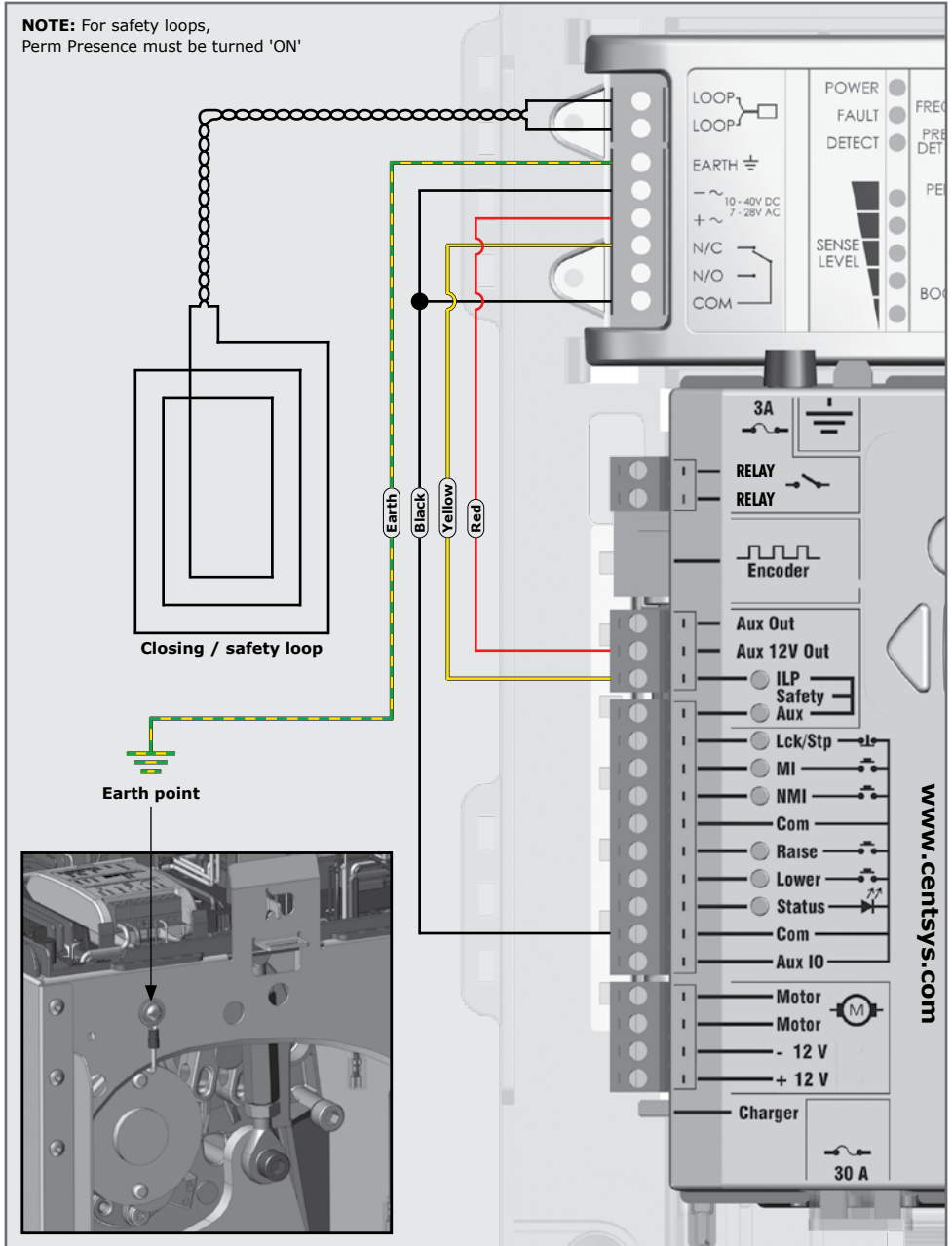


FIGURE 27. WIRING A SINGLE FLUX SA AS A CLOSING / SAFETY LOOP

### DIP switch settings:

For the settings and descriptions, see the pocket-guide provided with the FLUX SA.

#### 4.4.2. Installing dual FLUX SA loop detectors

If a free-exit loop is required in addition to the safety-loop, a second FLUX SA must be installed.

##### Step 1

Fit the second FLUX SA onto the electronics tray, and secure in place using the screws provided. (Figure 29).

##### Step 2

Wire the second FLUX SA to the controller using the supplied harness as per the wiring diagram (Figure 31).

##### Step 3

Run the TWISTED loop wires up inside the enclosure through the wiring clips to the second FLUX SA (Figure 30). Wire the twisted loop wires to the second FLUX SA. Take note of the wiring channel provided for the twisted loop wires.

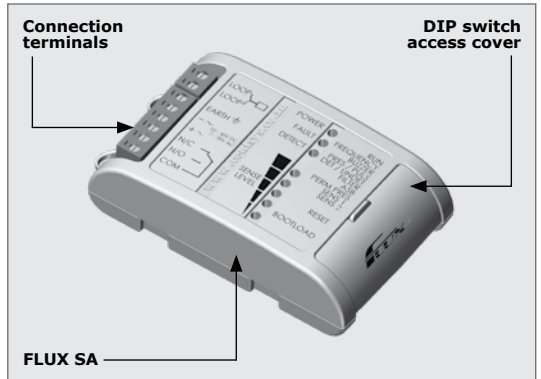


FIGURE 28

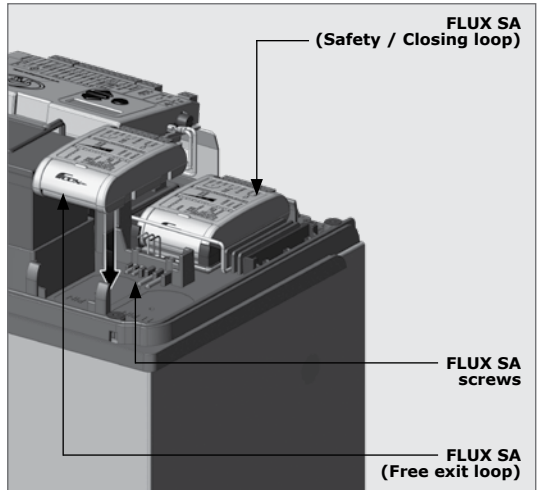


FIGURE 29

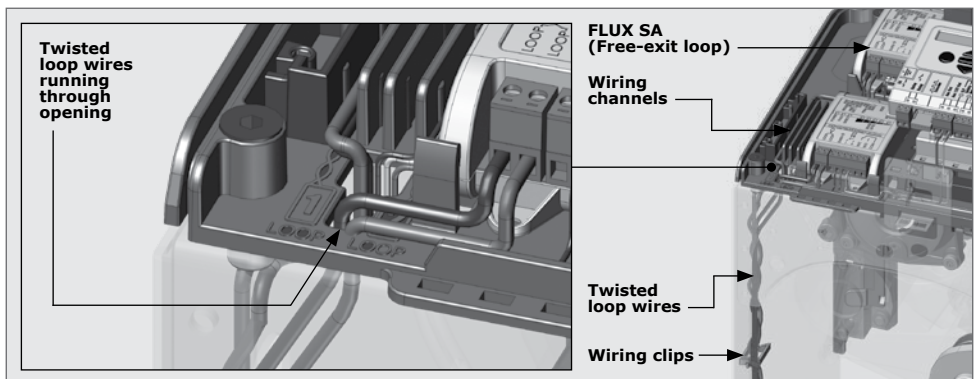


FIGURE 30

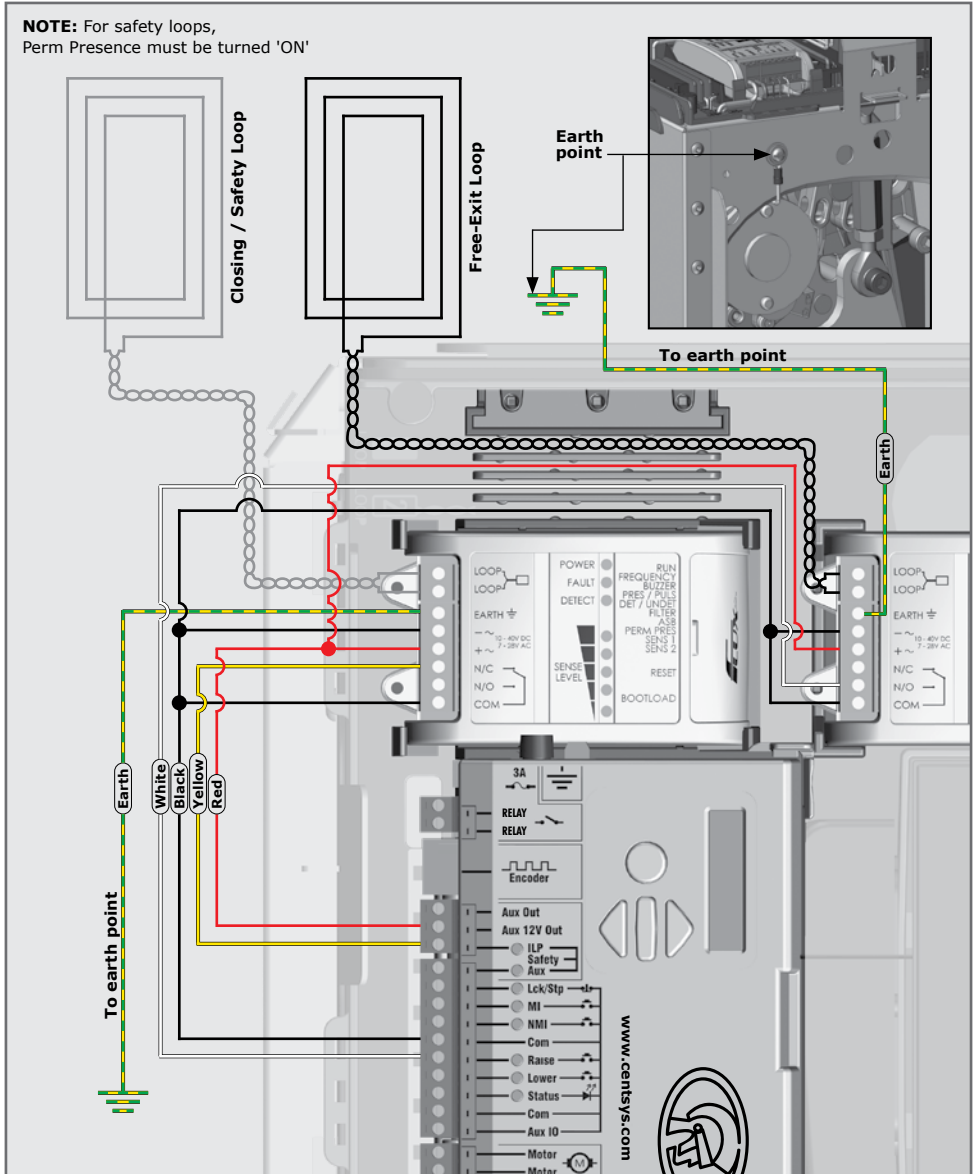


FIGURE 31. WIRING THE FLUX SA IN A DUAL LOOP CONFIGURATION



If FLUX 11-pin loop detectors are preferred, refer to Appendix 4 (Section 10.4) for the installation instructions and wiring.

## 5. Basic Controller Setup

### 5.1. Powering up the SECTOR II

The unit is now ready to be set up and programmed according to the installation requirements of the site. Switch the isolator 'ON' (to provide power to the battery charger) and connect the 12V battery wires to the battery. The battery should be installed in its holder and wired to the controller using the battery leads supplied.

### 5.2. Programming the controller

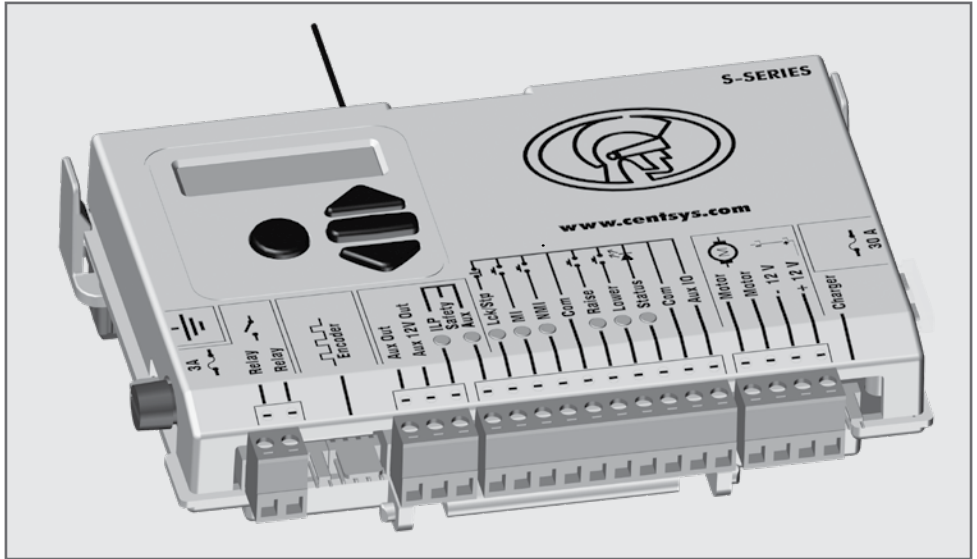


FIGURE 32. S-SERIES CONTROLLER

#### Menu 1 - Setting up the limits

When setting up the **SECTOR II** via the LCD display, follow all the stages that are shown on the display. To start the setup do the following:

- Press and hold the oblong (■) enter button for two seconds to enter Setup Mode
- If powering up for the first time (ex-factory), select the required profile that will suit your specific region (ZA - for South Africa, CE - for Europe and UL325<sup>1</sup> - for North America/ Canada)
- With this set, the system will automatically proceed to the Limit Setup menu. Follow the on-screen instructions to complete the setup procedure
- If powering up at any point after this, press and hold the oblong (■) enter button for two seconds to enter the programming menu again



1. The Regional Operating Profile is compliant with UL325 regulatory standard, but the barrier is not certified.

## Adjusting the spring tension

The controller will assist with adjusting the spring tension.

If the boom pole is badly out of balance, the controller will emit a beep each time the **SECTOR II** is operated (Figure 33 error message). The spring must be tensioned as described below. If the spring is within an acceptable tension window (Figure 34 message), adjustment is not necessarily required. However, the number in the block should ideally be zero.

### Step 1

Place the **SECTOR II** into Simplex Mode (Menu 4).

### Step 2

Access the spring adjustment menu by pushing the down arrow once when the unit is out of programming mode.



Only tension the spring when the boom pole is in the raised position.

If the pole is not balanced, refer to Figures 33 and 34.



To refresh the display, perform two complete cycles using the round button. This will update the number in the middle. Once it shows a 0 (zero), the spring is balanced. **Keep your hands clear of any mechanical parts whilst operating the barrier!**

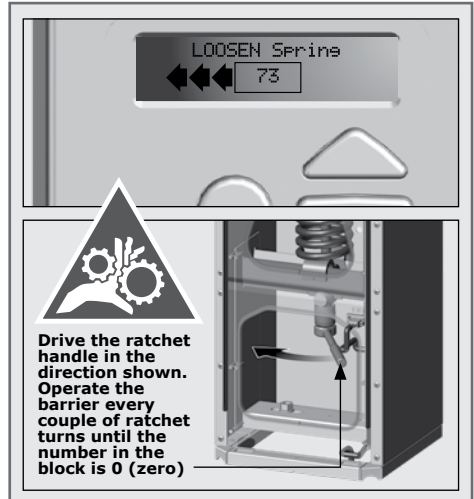


FIGURE 33. UNBALANCED SPRING

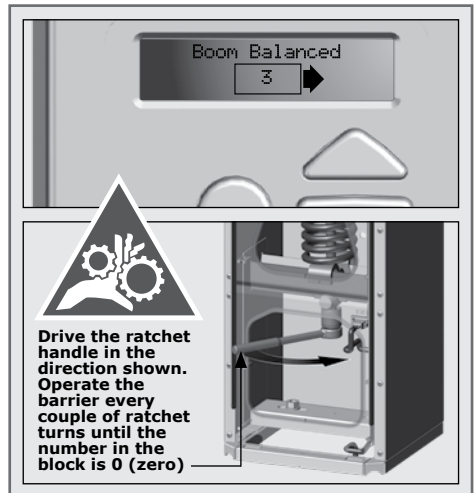


FIGURE 34. SPRING WITHIN BALANCE WINDOW

## Menu 2 - Safety Collision Force

The collision force can be set independently for raising or lowering operation, from minimum to maximum<sup>1</sup>, in five incremental steps. A sixth step will disable collision sensing entirely, allowing maximum force to be achieved. The motor will only shut down when its stall point is reached in this case. Stall-level is adjustable; refer to Torque-Limit under Menu 5.

The maximum force-setting should only be used if additional safety measures are taken; for example, inductive loops, etc. The response of the system to a collision will vary, depending on the operating standard (e.g. CE, UL325) selected.

### 2.1 Collision force

Collision force setting satisfies UL325, but the **SECTOR II** barrier itself is not certified.

### 2.2 Collision count

The number of sequential collisions that the system will allow, before shutting down the controller, if the boom pole does not reach the lowered position.

The counter resets each time the boom pole reaches its lowered position. A valid trigger input will clear the shutdown.

### 2.3 Collision Alarm Output

An alarm is activated if the multiple-collision-shutdown is triggered. This menu item configures the different alarm outputs.

### 2.4 LCK input as ESTOP

Allows the LCK (Holiday Lockout) input to be configured as an emergency-stop input.

1. Maximum does not imply maximum sensitivity to collision; it implies that the **SECTOR II** barrier will drive with maximum force.

## Menu 3 - Autolower

Refer to the advanced controller setup for more information (Section 7).

## Menu 4 - Modes of Operation

For a detailed explanation of the Modes of Operation provided by the **SECTOR II** traffic barrier, please refer to the appropriate section in the Buyer's Guide.

## Menu 5 - Run Profile

Refer to the advanced controller setup for more information (Section 7)

## Menu 6 - Setting up the Loop Detector(s) and testing

To set up the loop detector options, hold the middle oblong button for 2 seconds. Scroll to Menu 6: Loop Detectors.

### 6.1 ILAC (Inductive Loop Autoclose) Control

Causes the boom to Autolower as soon as the closing-inductive loop is cleared, i.e. the vehicle moves off the loop.

### 6.2 ILD Input to Output

This setting allows the status of the inductive-loop detector i.e. vehicle present or not present, to be indicated externally.

### 6.3 Roll back time

The boom pole will raise if a vehicle is detected within this period. Thereafter the boom will not raise.

#### 6.4 FRX (Free-exit) loop direction

Allows a single access point with bi-directional traffic to make use of a free-exit loop. Due consideration must be given to closing and free-exit loop positioning.

#### 6.5 Presence Alarm

If enabled and while the boom pole is lowered an alarm will be activated if the closing-loop has been continually active for a predefined time. The alarm will remain activated while the closing-loop remains activated.

- **Function Output** - Allows the alarm to be mapped to an output on the controller
- **Presence time** - The time for which the closing-loop must be continuously activated before the alarm is activated

Once the required changes are made, exit the menu by pressing the round button.

#### Menu 7 to Menu 14

Refer to the advanced controller setup for more information (Section 7)

## 6. Installation Handover

Once the installation has been successfully completed and tested, it is important to explain the operation and safety requirements of the system to the end-user.

### **NEVER ASSUME THE USER KNOWS HOW TO SAFELY OPERATE AN AUTOMATED BARRIER!**

Even if the user has used one before, it does not mean he knows how to SAFELY operate it. Make sure that the user fully understands the following safety requirements before finally handing over the site.

The following needs to be understood by the user:

- How to operate the manual release mechanism  
**(Show them how by demonstration)**
- How the safety loops and all other safety features work  
**(Show them how by demonstration)**
- All the features and benefits of the operator, i.e. Safety loops, etc
- **All the safety considerations associated with operating an automated barrier. The user should be able to pass this knowledge on to all other users of the automated system and must be made aware of this responsibility**

- Do not activate the barrier unless you can see it and can determine that its area of travel is clear of people, pets, or other obstructions
- **NO ONE MAY GO UNDER A MOVING BARRIER.** Always keep people and objects away from the barrier
- **NEVER LET CHILDREN OPERATE OR PLAY WITH THE BARRIER CONTROLS,** and do not allow children or pets near the barrier area
- Be careful with moving parts and avoid close proximity to areas where fingers or hands could be pinched
- Secure all easily-accessed barrier operator controls in order to prevent its unauthorised use
- Keep the automated barrier system properly maintained, and ensure that all working areas are free of objects that could affect its operation and safety
- On a monthly basis, check the obstruction detection system and safety devices for correct operation
- All repair and service work to this product must be done by a suitably qualified person
- This product was designed and built strictly for the use indicated in this documentation. Any other use, not expressly indicated here, could compromise the good condition/operation of the product and/or be a source of danger!



Neither Centurion Systems (Pty) Ltd, nor its subsidiaries, accepts any liability caused by improper use of the product, or for use other than that for which the automated system was intended.

**Ensure that the customer is in possession of the user guide and that you have completed the installation details in the back of the manual.**

## Standard installation is now complete


At this point, a simple installation of a **SECTOR II** has been completed. Should the installation require other adjustments to be made to the standard settings, these can be found from Section 7 onwards. We recommend that these menus be carefully considered and adjustments applied to the installation, if required.

## 7. Advanced Controller Setup

### Setting up additional features for the SECTOR II barrier

The **SECTOR II** navigation map (Section 7.1), provides the full menu of features that can be set up on the system.

A brief explanation of each feature is provided under each menu heading. When setting up additional features, all the stages that have to be followed are clearly provided via the display. It is only necessary to note the following:

- To get into Setup Mode, press and hold the oblong (  ) enter button for two seconds and follow the onscreen instructions
- The buttons provided on the controller for navigating the system are blank because their functions vary within each menu and are indicated on the LCD display

### 7.1. Menu navigation map for the S-SERIES controller



#### 1. Setting Limits



#### 1.1. Setup Wizard



#### 2. Safety

##### 2.1. Collision Force

##### 2.1.1. Raising Collision Force

##### 2.1.2. Lowering Collision Force

##### 2.2. Collision Count

##### 2.3. Collision Alarm Output

##### 2.4. LCK Input as ESTOP



#### 3. Autolower

##### 3.1. Autolower Status

##### 3.2. Autolower Timer

##### 3.3. Autolower Override

##### 3.4. Autolower Advanced Options

##### 3.4.1. Autolower When Fully Raised

##### 3.4.2. Autolower When Partly Raised

##### 3.4.3. Autolower When Partly Lowered



#### 4. Modes of Operation

##### 4.1. Operating Mode

##### 4.1.1. Select Mode Simplex

##### 4.1.2. Select Mode Complex

##### 4.1.3. Select Mode PLC

##### 4.1.4. Select Mode Spike



## 5. Run Profile

- 5.1. End Stop Options
  - 5.1.1. Hold At Raised
  - 5.1.2. Hold At Lowered
  - 5.1.3. Hold Force
- 5.2. Raise When Mains Fail
- 5.3. Pre-Rsg Delay (Delay Before Raising)
- 5.4. Pre-Lwg Delay (Delay Before Lowering)
- 5.5. Raising Speed
- 5.6. Lowering Speed
- 5.7. Ramp Up Distance
- 5.8. Ramp Down Distance
- 5.9. TRG STOP Distance (Trigger STOP Distance)
- 5.10. Loop STOP Distance
- 5.11. Crawl Distance
- 5.12. Torque Limit



## 6. Loop Detector

- 6.1. ILAC Control (Inductive Loop Autoclose)
- 6.2. ILD Input to Output (Inductive Loop Detector Input to Output)
- 6.3. Rollback Time
- 6.4. FRX Loop Direction (Free Exit Loop Direction)
- 6.5. Presence Alarm
  - 6.5.1. Function Output
  - 6.5.2. Presence Time



## 7. Traffic Light

- 7.1. Function Output
- 7.2. Trigger Level



## 8. Barrier Status

- 8.1. Function Output
- 8.2. State Configuration
  - 8.2.1. Lowered Indication
  - 8.2.2. Partly Lowered Indication
  - 8.2.3. Lowering Indication
  - 8.2.4. Raised Indication
  - 8.2.5. Partly Raised Indication
  - 8.2.6. Raising Indication
  - 8.2.7. Unknown Indication



## 9. Ticket Vending

- 9.1. Function Output
- 9.2. Polarity



## 10. Courtesy Light

- 10.1. Function Output
- 10.2. Light Profile
- 10.3. Light Timer



## 11. Spikes Control

- 11.1. Spikes Mode



## 12. ChronoGuard

- 12.1. Time and Date
- 12.2. Time Periods
  - 12.2.1. Add Time Period
    - 12.2.1.1. Auto Function
    - 12.2.1.2. Time-bar Function
  - 12.2.2. Delete Time Period
  - 12.2.3. Edit Review Time Period
- 12.3. Exclusions
  - 12.3.1. Add Exclusion
    - 12.3.1.1. Auto Function
    - 12.3.1.2. Time-bar Function
  - 12.3.2. Delete Exclusion
  - 12.3.3. Edit Review Exclusion
- 12.4. Delete All Time Periods and Exclusions



## 13. General Settings

- 13.1. Operating Standard
- 13.2. Reset Options
  - 13.2.1. Factory Defaults
  - 13.2.2. Delete All Remotes
  - 13.2.3. Delete All Time Periods and Exclusions
  - 13.2.4. Reset All
- 13.3. Diagnostic Screen Status
- 13.4. Round Test Button Status
- 13.5. Backup EEPROM
- 13.6. Restore EEPROM
- 13.7. Charger Type

**14. Remote controls - Press button of valid transmitter (if menu is locked)**

14.1. Add Remotes

14.2. Delete Remotes

14.2.1. Delete by ID

14.2.2. Delete button

14.2.3. Delete by button

14.2.4. Delete not present

14.2.5. Delete all remotes

14.3. Edit Remote Button

14.4. Autolearn Remotes

14.5. Tx Menu Locked

14.6. Onboard Receiver Status

## The following provides additional information of each menu.

### Menu 1 and Menu 2

Refer to the basic controller setup for more information (Section 5).

### Menu 3 - Autolower

The **SECTOR II** can be set to Autolower the boom under many different circumstances. The following options are available;

#### 3.1 Autolower status

If enabled, the boom pole will automatically lower after a preset Autolower time.

#### 3.2 Autolower time

The Autolower time can be set anywhere from 1 to 240 seconds (four minutes).

#### 3.3 Autolower override

If turned on, this menu provides a way for a user to temporarily turn off Autolower. To achieve the functionality, the user would activate and maintain the Memory Input for longer than the Autolower Override Time. Activate Memory Input to clear the override.

#### 3.4 Autolower advanced options

Set the conditions under which the boom pole will automatically lower. More than one condition can be selected:

- **Autolower fully raised**  
Automatically lower the boom if boom pole is fully raised
- **Autolower on partly raised**  
Automatically lower the boom pole if it has been stopped partially raised
- **Autolower on partly lowered**  
Automatically lower the boom pole if it has been stopped partially lowered

### Menu 4 - Modes of Operation

Refer to the Pre-installation Buyer's Guide for more information.

### Menu 5 - Run Profile

The run profile of the **SECTOR II** can also be set. This allows the overall behaviour of the traffic barrier to be fine-tuned in order to meet the user's unique requirements;

#### 5.1 End Stop Options

The SECTOR II is supplied in Fail-safe Mode (Default), meaning that the boom can be manually moved from the raised or lowered positions without the need of the Override Tool.



The endstops must be configured in the unlocked (fail-safe) positions, Refer to Section 10.3 to adjust the endstops accordingly.

##### 5.1.1 Hold At Raised<sup>1</sup>

If enabled, the boom will be electronically held at the raised position, allowing the boom pole to be manually lowered if required.

### 5.1.2 Hold At Lowered<sup>1</sup>

If enabled, the boom will be electronically held at the lowered position, allowing the boom pole to be manually raised if required.

### 5.1.3 Hold Force<sup>1</sup>

The electronic force that will be used to hold the boom pole in the lowered or raised position.

1. The endstops must be configured in the unlocked (fail-safe) positions, Refer to Section 10.3 to adjust the endstops accordingly.

Should the installation require the use of the Override Tool (mechanical locking) to override the boom pole, the following steps need to be followed;



- Disable Hold At Raised or Hold At Lowered as required
- Configure the relevant endstops in the locked positions, Refer to Section 10.3 to adjust the endstops accordingly.

## 5.2 Raise when mains fail

If enabled, the boom pole will raise in event of a mains power failure. Boom pole will remain raised until mains power is restored.

## 5.3 Pre-raising delay

Allows a delay between a valid trigger signal and the boom pole raising. Can activate a warning light during delay if the TVI is not selected. (Refer to pre-flash modes of the courtesy light feature, for more details.)

## 5.4 Pre-lowering delay

Identical to above, except for boom pole lowering.

## 5.5 Raising speed

Sets the maximum raising speed in degrees per second.

## 5.6 Lowering speed

Sets the maximum lowering speed in degrees per second.

## 5.7 Ramp-up distance

Sets the ramp-up distance in degrees.

## 5.8 Ramp-down distance

Sets the ramp-down distance in degrees of travel of the boom pole when stopping.

## 5.9 TRG stop distance

Sets the angle over which a moving boom pole will stop after a trigger signal is received.

## 5.10 Loop stop distance

Sets the angle over which a moving boom pole will stop after a safety input is triggered.

## 5.11 Crawl distance

Sets the final crawl distance in degrees of travel of the boom pole when reaching an endpoint.

## 5.12 Torque limit

Sets the maximum torque delivered by the motor. This is useful in cases where limited push force is required.

## Menu 6 - Loop Detector

Refer to the basic controller setup for more information (Section 5).

## Menu 7 - Traffic Light

The **S-SERIES** controller provides the facility to control an externally-mounted traffic light (The traffic light is an ancillary product and may be purchased from Centurion Systems (Pty) Ltd). The purpose of the traffic light is to signal to road users that it is safe to travel across the barrier threshold.

### 7.1 Traffic Light Function Output

The traffic light feature is enabled or disabled in this menu. The logic signalling of the feature is routed to a physical controller output based on the setting specified in this menu. There are six physical controller outputs that are available for output routing. The outputs are listed in the table below, along with the relevant electrical characteristics of the respective outputs:

Output setting on controller	Output Description	Output Type	Electrical Switch Characteristics
<b>OFF</b>	This will disable the Traffic Light indication		
<b>RLY</b>	Relay	Dry Contact	24V DC/250V AC, 2A contact
<b>XIO</b>	Aux IO	Open Drain	Open Drain – 3A sink current, with a 3V floating terminal Voltage.
<b>AUX</b>	Aux Out	Open Drain	Open Drain – 3A sink current
<b>LED</b>	Status LED	Open Collector	Open Collector 5V – 50mA Source
<b>BUZ</b>	Buzzer	Audible	No connection

**TABLE 3**

### 7.2 Trigger Level

Specifies the arc angle that triggers the transition of the relevant output signal from an inactive state to an active state. From 0 degrees up to but excluding the specified angle<sup>2</sup>, the output is always inactive (normally-open, or floating depending on the configured output used). From the specified angle through to 90 degrees inclusively, the output is active (normally-closed, or active low depending on the configured output used). The Trigger Level is specified as an arc angle, measured in degrees. The angle is measured with respect to the horizontal (0 degrees), increasing in the opening or raising direction of the barrier.

1. Please note that it should not be taken for granted that the traffic light feature will always be enabled by default. Future statutory requirements may dictate that this feature is not enabled by default in one or other of the operating profiles.
2. For the purposes of clarity, in the event that the Trigger Level is set to 0 degrees, the output will transition to the active state as soon as the barrier transitions to the RAISING state. In other words, the traffic light will go green as soon as a raising command is executed by the **SECTOR II**.

## Menu 8 - Barrier Status

The **S-SERIES** controller provides a feature to indicate a barrier operating state (e.g. Lowered, Raising, Raised, etc), or set of states, to an external device. The purpose of this is to signal the operating condition of the **SECTOR II** barrier to some external piece of equipment (e.g. Interlocked access control equipment such as another barrier or a gate operator, programmable logic controllers, alarm systems, etc).

## 8.1 Barrier Status Function Output

The Barrier Status Indication feature can be turned ON or OFF, independent of any other settings associated with the feature.

The logic signalling of the feature is routed to a physical controller output based on the setting specified in this menu. There are six physical controller outputs that are available for output routing as shown below:

Output setting on controller	Output Description	Output Type	Electrical Switch Characteristics
<b>OFF</b>	This will disable the Traffic Light indication		
<b>RLY</b>	Relay	Dry Contact	24V DC/250V AC, 2A contact
<b>XIO</b>	Aux IO	Open Drain	Open Drain – 3A sink current, with a 3V floating terminal Voltage.
<b>AUX</b>	Aux Out	Open Drain	Open Drain – 3A sink current
<b>LED</b>	Status LED	Open Collector	Open Collector 5V – 50mA Source
<b>BUZ</b>	Buzzer	Audible	No connection

TABLE 4

## 8.2 State Configuration

Each of the seven operating states can be independently configured to drive the output active (ON) or inactive (OFF) according to the table below. The RAISING and LOWERING states offer additional configuration options, allowing the output to transition to an active or inactive state if the barrier is above or below a particular arc angle.

- In the RAISING state, the output will start in the inactive state, and transition to the active state if the barrier is at or above the specified arc angle
- In the LOWERING state, the output will start in the active state, and transition to the inactive state if the barrier is at or below the specified arc angle

Barrier State	Option		
<b>Lowered Indication</b>	OFF	ON	
<b>Part Lowered Indication</b>	OFF	ON	
<b>Lowering Indication</b>	OFF	ON <sup>3</sup>	5°, 10°, 15°, 20°,... 80°, 85°
<b>Raised Indication</b>	OFF	ON	
<b>Partly Raised Indication</b>	OFF	ON	
<b>Raising Indication</b>	OFF	ON <sup>1</sup>	5°, 10°, 15°, 20°,... 80°, 85° <sup>2</sup>
<b>Unknown indication</b>	OFF	ON	

TABLE 5

1. The output will transition to the active state as soon as the barrier transitions to the RAISING state.
2. The arc angle is specified in degrees. The angle is measured with respect to the horizontal (0°), increasing in the opening or raising direction of the barrier.
3. The output will transition to the active state as soon as the barrier transitions to the LOWERING state.

## Menu 9 - Ticket Vendor Interlock (TVI) Output

The Ticket Vendor Interlock feature provides an interlocking mechanism between a ticket vending machine, and the **SECTOR II** barrier.

In the interlock configuration, the ticket vending equipment activates the barrier when a ticket for access is validly issued. The barrier now needs to interlock (prevent) further tickets from being issued while the barrier is raised. The interlock expires when the barrier reaches the closed position again.

### 9.1 TVI Function Output

The NMI input will react differently depending on whether the TVI feature is enabled or not. The NMI input will react as follows;



If the TVI feature is Enabled, the barrier will only activate when the NMI input is released, that is, when the NMI input is connected to COM via a switching circuit, the barrier will only activate when the switching circuit opens.

If the TVI feature is Disabled, the barrier will activate when the NMI input is activated, that is, when the NMI input is connected to COM via a switching circuit, the barrier will activate as the switching circuit closes.

The outputs are listed in the table below, along with the relevant electrical characteristics of the respective outputs:

Output setting on controller	Output Description	Output Type	Electrical Switch Characteristics
<b>OFF</b>	This will disable the Traffic Light indication		
<b>RLY</b>	Relay	Dry Contact	24V DC/250V AC, 2A contact
<b>XIO</b>	Aux IO	Open Drain	Open Drain – 3A sink current, with a 3V floating terminal Voltage.
<b>AUX</b>	Aux Out	Open Drain	Open Drain – 3A sink current
<b>LED</b>	Status LED	Open Collector	Open Collector 5V – 50mA Source
<b>BUZ</b>	Buzzer	Audible	No connection

**TABLE 6**

### 9.3 TVI Output Polarity

The **SECTOR II** can be used with various ticket vending equipment. To accommodate this flexibility, the polarity of the interlock signal can be reversed in situations where the ticket vending equipment is not directly compatible in the standard configuration of the interlock signal.

<b>N/C</b>	Physical output is normally-closed or active low (depending on output specified) when the interlock is active
<b>N/O</b>	Physical output is normally-open or floating (depending on output specified) when the interlock is active.

**TABLE 7**

## Menu 10 - Courtesy Light

The courtesy light circuit on the controller is a convenient way to electronically coordinate the behaviour of pillar lights, or security lights, with the movement of the traffic barrier. Typically the courtesy lights will switch on when the barrier is triggered, and stay on for a period of time after the barrier lowers to illuminate the area around the barrier for the sake of both security and convenience. However, the courtesy light circuit has a number of other useful profiles that can be configured to control the behaviour of the light in different situations. The general functional behaviour of each profile is highlighted in Section 10.3.

### 10.1 Courtesy Light Function Output

The courtesy light feature can be turned ON or OFF, independent of any other settings associated with the feature. The courtesy light feature is turned off by default.

The outputs are listed in the table below, along with the relevant electrical characteristics of the respective outputs:

Output setting on controller	Output Description	Output Type	Electrical Switch Characteristics
OFF	This will disable the Traffic Light indication		
RLY	Relay	Dry Contact	24V DC/250V AC, 2A contact
XIO	Aux IO	Open Drain	Open Drain – 3A sink current, with a 3V floating terminal Voltage.
AUX	Aux Out	Open Drain	Open Drain – 3A sink current
LED	Status LED	Open Collector	Open Collector 5V – 50mA Source
BUZ	Buzzer	Audible	No connection

TABLE 8

### 10.2 Courtesy Light Profile

One of four lighting profiles can be selected based on the table below:

Light Profile	Profile Description
CUR	Courtesy Light Profile
PFA	Pre-Flash A
PFB	Pre-Flash B
PFC	Pre-Flash C

TABLE 9

The profile controls the light to act as a courtesy light. Any barrier activation will switch on the light. The light stays on while the barrier moves, or during any form of pre-delay. Once the barrier is stationary, the light will remain on for the time set by the 'Courtesy Light Time' setting. After which, the light will switch off.

**Pre-Flash A Profile (PFA)** – The light will only switch on while the barrier is moving. The light will switch off or remain off in all stationary states, even those states that pre-empt movement (pre-open delay, pre-close delay)

**Pre-Flash B Profile (PFB)** – The light will flash while the barrier is moving, and during any states that pre-empt movement (pre-open delay, pre-close delay)

**Pre-Flash C Profile (PFC)** – The light behaves identically to Pre-Flash B profile except it doesn't flash, it simply switches on.

PULL OUT

## SECTOR II Installation flow diagram pull-out



These two pages pull out and can be used for easy reference when installing your **SECTOR II** high-volume traffic barrier.

PULL OUT



**FLOW CHART  
INSIDE**

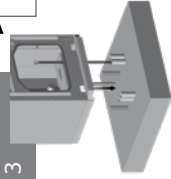
PULL OUT

# Installation flow diagram

Pre-installation  
(refer to pre-installation buyers guide)



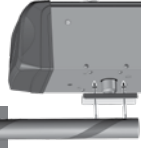
Mount the cabinet  
Section 3



Changing orientation  
Section 10.2



Fit the pole  
Section 3.2



Earth and mains  
Section 4.1



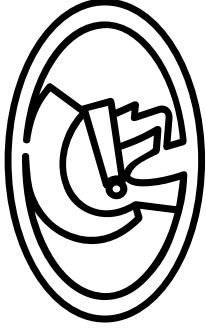
AC and DC isolators  
Section 4.3



Install 11-pin loop detector(s)  
Section 10.4

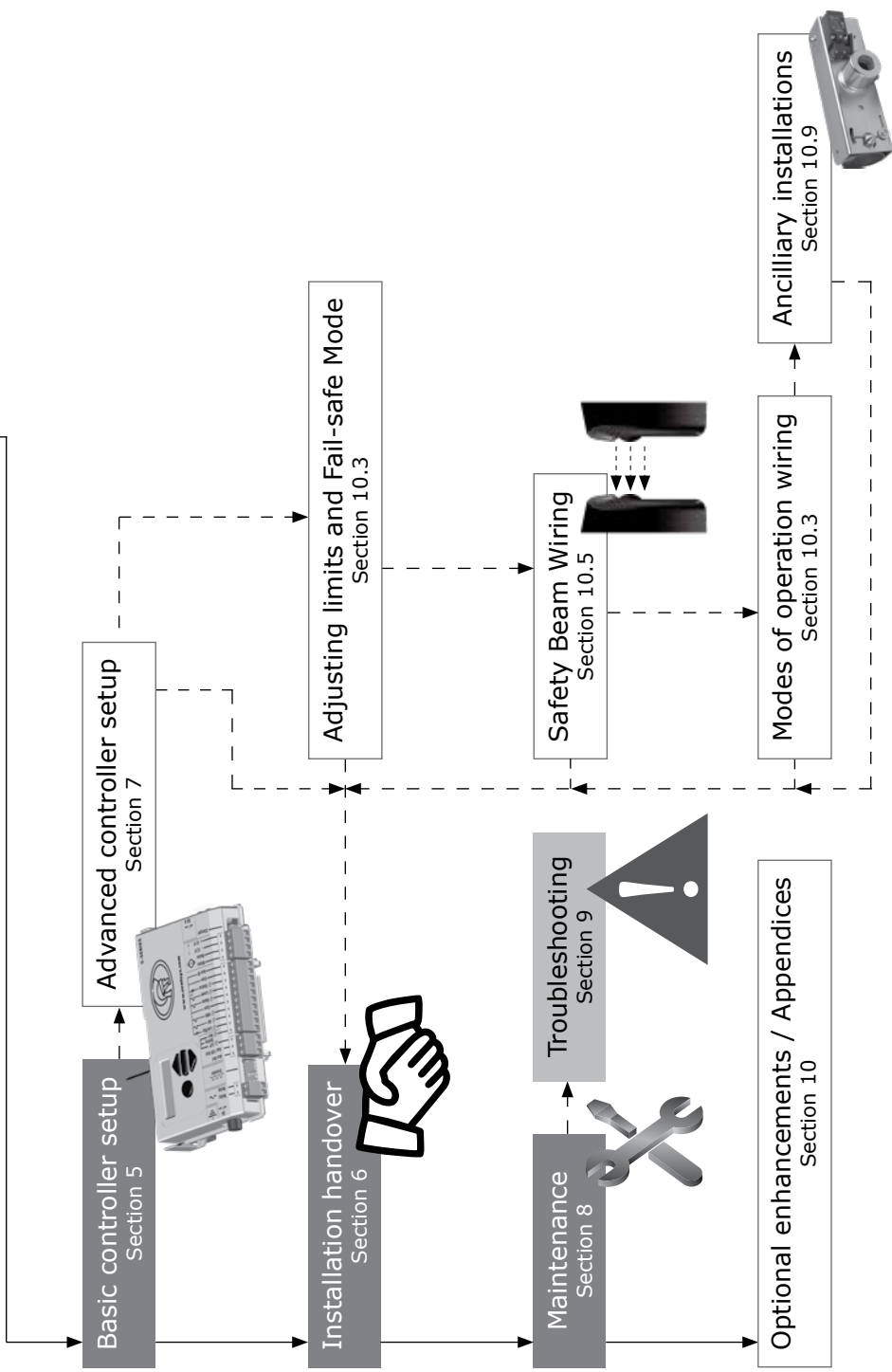


Install FLUX SA loop detector(s)  
Section 4.4



## Key Chart

1	Installation mainstream
2	Sub installations
3	Optional



PULL OUT

## SECTOR II Installation flow diagram pull-out



These two pages pull out and can be used for easy reference when installing your **SECTOR II** high-volume traffic barrier.



**FLOW CHART  
INSIDE**

PULL OUT

PULL OUT

### 10.3 Courtesy Light Timer

When the pole comes to rest after any form of barrier movement (manual movement of the barrier is discounted), the controller enters a courtesy light phase. During this period, if the courtesy light profile is enabled, the courtesy light will switch on (or remain on). At the end of the courtesy light period, the light will switch off.

The 'Courtesy Light Time' setting specifies the time period of the courtesy light phase. It can be set from 4 seconds to 9h59m59s in 1 second increments.

### Menu 11 - Spikes Control

This menu determines how the S-SERIES controller interacts with the CLAWS Spikes modules. Spikes Control will interface / control Standalone or Direct Drive Spikes. The spikes interface enables the electrical communications interface and functional barrier behaviour that allows the S-Series Controller to interface with Spikes hardware. CENTURION offers two CLAWS units that are compatible with the SECTOR II barrier. Refer to the CLAWS literature for further information on this product range.

#### 11.1 Spikes Interface

The spikes interface enables the electrical communications interface and functional barrier behaviour that allows the S-Series Controller to interface with Spikes hardware. CENTURION offers two CLAWS units that are compatible with the **SECTOR II** barrier. Refer to the CLAWS literature for further information on this product range.

#### 11.2 Spikes Mode

The Spikes Mode setting configures the S-Series Controller to control the specific operational behaviour of the spikes and the barrier in combination. There are three Modes of Operation:

**OFF – Disables Spikes interface:** This mode will allow the S-Series Controller to operate in standalone mode.

**SAF - Safe Mode:** This mode is only applicable to an Independent Drive system. In this mode, the barrier will only raise when the S-Series Controller has confirmed that the spikes have reached their fully lowered position. When the S-Series Controller is commanded to lower the barrier, the barrier must reach the fully lowered position, before the raise signal is issued to the CLAWS Controller.

**SEC - Secure Mode:** This mode is only applicable to an Independent Drive system. In this mode, the S-Series Controller will raise the barrier at the same time that the lower signal is issued to the CLAWS Controller (causing the spikes to start to lower). Similarly, the S-Series Controller will lower the barrier at the same time raise signal is issued to the CLAWS Controller (causing the spikes to start to raise).

**DIR - Direct Drive Mode:** This mode is only applicable to a Direct Drive CLAWS system. In this mode, the S-Series Controller will only turn the traffic light green when the spikes are in their fully lowered position. In any spikes orientation other than fully lowered orientation, the traffic will remain in a red state.

### Menu 12 - ChronoGuard (Time-periods) A World First

#### 12.1 Time and Date

ChronoGuard allows automatic activation or time-barring (prevented operation) of specific controller inputs, and the time-barring of specified remote control buttons used together with the onboard receiver. The Real-Time Clock and Calendar will maintain time-keeping for a minimum of one hour without any power.



In both cases, the relevant sensors must be installed for the system to operate safely and correctly.

## 12.2 Time-periods

A Time-period is defined by a start and end date and time. Up to 100 Time-periods can be defined. A Time-period can be set as a once-off event or repeated on a weekly or annual basis. The weekly repeat can be chosen to occur on every day of the week, weekdays only, weekends only, or any specific day. The minimum duration of a Time-period is one minute. Once-off time periods have the highest precedence, followed by annual and then weekly.

### Auto-functions (Auto-activations)

Automatically activate any of the listed inputs/outputs during a time-period.

#### Inputs

- Barrier-raise
- Barrier-lower
- Barrier-disable (LCK) - also referred to as 'Holiday Lockout'
- Closing-loop (ILD)

#### Outputs

- Aux Out - this is an open-collector transistor output, switching to negative, used to drive an external relay for operating any external device
- Aux IO - this is a switching negative used to drive an external relay for operating any external device

### Time-barring

Time-barring of inputs is divided into physical inputs and outputs mapped to a remote control button. The following physical inputs can be time-barred (prevented from operating) during a Time-period:

- Barrier-raise
- Barrier-lower
- Memory Input (MI)
- Non-memory Input (NMI)
- Barrier-disable (LCK)

The following physical outputs can be time-barred (prevented from operating) during a Time-period:

- TVI (configured as a relay to switch a Courtesy Light )
- The following remote control inputs can be time-barred (prevented from operating) during a Time-period:
  - Barrier-raise
  - Barrier-lower
  - Memory Input (MI)
  - Non-memory Input (NMI)
  - Barrier-disable (LCK)

The Time-barring of code-hopping transmitters is specified at the time of coding the transmitter into the system. Once an RF input is defined as time-barred, any time-barred transmitter associated with that input will be time-barred during the relevant time-period. If a physical/ RF input is time-barred, any attempt to activate it will be acknowledged by a short beep of the onboard buzzer. The input, however, will not activate.

### 12.3 Exclusions

Exclusions are used to prevent scheduled Time-periods from occurring at specific times (e.g. public holidays). While time-barring can be used to achieve a similar end, exclusions can also be used to exclude time-barring itself. Each exclusion consumes one Time-period. Exclusions have the highest precedence, followed by time-barring and then auto-functions.

### 12.4 Delete all Time-periods and exclusions

Override to delete all values.

## Menu 13 - General Settings

### 13.1 Operating standard

Configure the controller to conform to the specific region's standard - e.g. UL325 or CE.

### 13.2 Reset options

- Factory defaults - Restore only the original factory defaults for the operating standard / profile chosen; no other settings are affected
- Delete all remotes - Delete all the remotes stored in the system; no other settings are affected
- Delete all time periods and exclusions - Delete all time periods and exclusions stored in the system; no other settings are affected
- Reset all - Clears the controller completely as per an off-the-production-line unit

*Boom pole end-of-travel limits are not affected by any reset*

### 13.3 Diagnostic screen

Allows a diagnostic screen to be displayed.

### 13.4 Round test button

Disables or enables the operation of the round test-button on the controller

### 13.5 Backup EEPROM

All settings excluding the boom pole end-of-travel limits are backed up to the Back Up Module.

### 13.6 Restore EEPROM

Restore all backed up settings from the Back Up Module to the S-Series Controller.

### 13.7 Charger Type - Charger

Mains Voltage monitoring will continue to function, if Mains Voltage fails the unit will alarm accordingly.

Solar, Mains Voltage monitoring is suspended, this allows the use of Solar Power without the constant Mains Voltage alarm indication.

## Menu 14 - Adding remote controls into the system

Up to 500 remote control transmitter buttons can be learned into the memory. Each transmitter learned into the system is assigned a unique transmitter ID. In multi-button remotes it is possible to use one of the buttons as a 'shift-button' allowing six functions on a four-button remote. When adding transmitters, it is recommended that a record be kept of the ID number allocated by the system to each respective transmitter and the person to whom the transmitter is given. This is necessary should selective deletion be required at a later stage.

- If the remote controls menu has been 'locked' as discussed later, only by pressing a button of a transmitter learned into the system, can this menu be accessed

- It is possible to artificially increase the number of buttons of a multi-button transmitter by using a two-button combination
  - One of the buttons is used as a shift button to allow the other buttons to be used again in combination with this button. In other words, the user will press and hold the shift button, before pressing one of the other buttons to create a new button
  - The shift button cannot be used as a button on its own, it must always be used in combination with the other buttons

#### **Benefits of the shift button system:**

- Use of the shift button system allows a three-button transmitter to gain an extra button and operate four functions and likewise a four-button transmitter gains two extra buttons and can operate six functions
- Another benefit of using the shift button system is that it requires both hands to operate the two-button combination. This prevents the user from accidentally enabling sensitive functions such as Holiday Lockout on the controller
- Each transmitter learned into the system is assigned a unique transmitter ID

#### **14.1 Add remote**

Any button can be set to control the memory, non-memory, raise boom pole, lower boom pole and Holiday Lockout inputs

#### **14.2 Delete remote**

Transmitters can be deleted at any stage according to one of the following methods:

- Delete remote by ID - Where a record of the unique ID has been kept, delete transmitter according to this ID. It is not necessary to have the remote present to delete the ID
- Delete remote button - Clear operation of a button on a particular transmitter. The transmitter has to be present
- Delete remote by button - Delete a transmitter that is present
- Delete-not-present - Allows a time-period to be set in hours. Any remotes which have not been used within the time-period will be deleted
- Delete all remotes - Clear the entire memory of all remotes

#### **14.3 Edit remote button**

Move the function from one button to another. The transmitter must be present.

#### **14.4 Autolearn**

Allows a Time-period to be set, during which any specific button will be learned to a specific function when it is pressed. The function will also be activated when the button is pressed. After the Time-period has expired, Autolearn is disabled, and no further buttons will be learned.

#### **14.5 Tx Menu locked**

Lock the remote controls menu and prevent unauthorised addition of new transmitters. Once enabled, the remote controls menu can only be accessed by pressing a valid transmitter button.

#### **14.6 Onboard receiver disable/enable**

Disables/Enables onboard receiver.

## 8. Maintenance

### 8.1.1 How and when to do maintenance

Maintenance should be carried out at regular intervals.

The list below can be used as a schedule for maintenance procedures.

As a minimum, the following maintenance procedures should be performed on a basis that is consistent with the daily usage of the unit:

1. Remove the DOSS Sensor and check whether it is in good working condition. Do this by first removing the DOSS from the gearbox, then cleaning the sensor, removing all dust and dirt from the optic sensors
2. Check the battery under load; it must not drop below 10,5V. Use the information screen to monitor the voltages. Check the battery terminals for signs of acid leakage, and, if necessary, clean the terminals and battery leads
3. Disconnect the battery and ensure that the charger delivers 14.20V on the relevant information screen
4. Check all the wires going into the connectors for tightness and remove any dirt that has accumulated

### 8.1.2 Mechanical checks

Tighten the M8 nuts securing the pole to the boom-coupler (Figure 35).

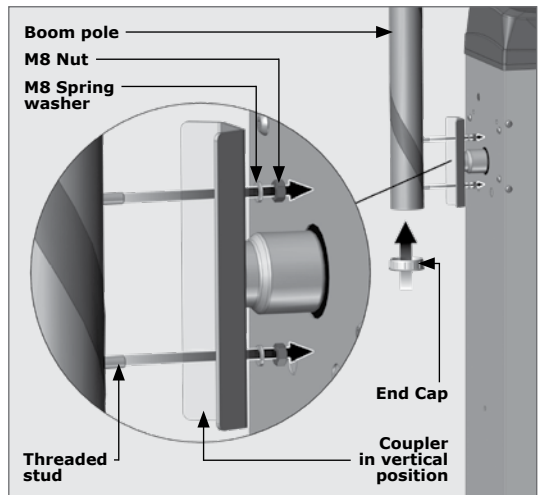


FIGURE 35

Ensure that the barrier is still bolted tightly to the plinth (Figure 36).

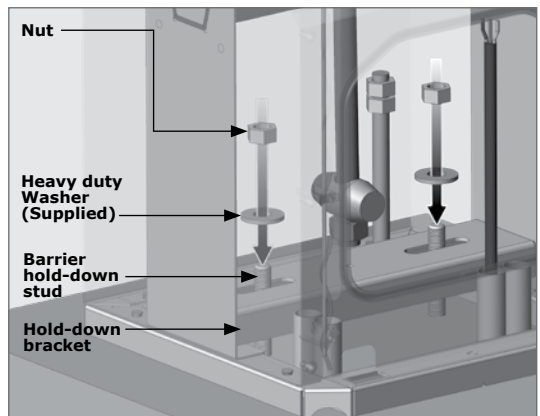


FIGURE 36

Check that the barrier pole is level and adjust if necessary using the adjustment link and its lock nuts (Figure 37).

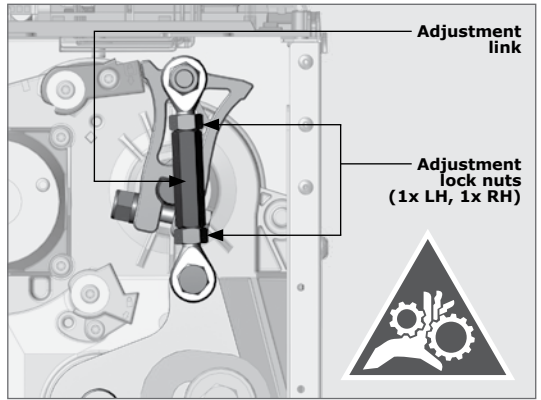


FIGURE 37

Tighten the two bolts on either side on the Adjustment Link, and the nut on the Drive Arm to 45Nm (Figure 38).

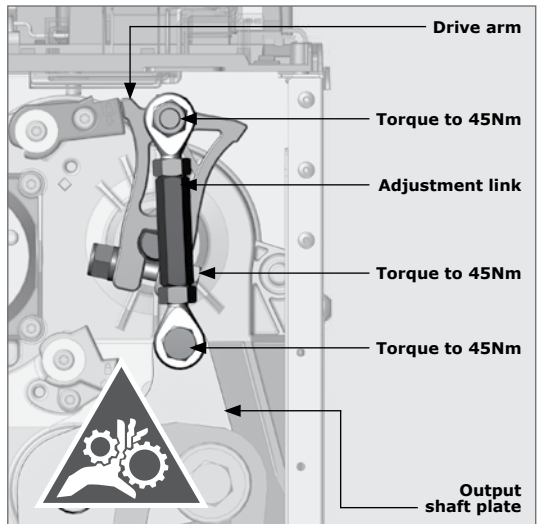


FIGURE 38

Tighten both endstops or replace them if necessary (Figure 39).

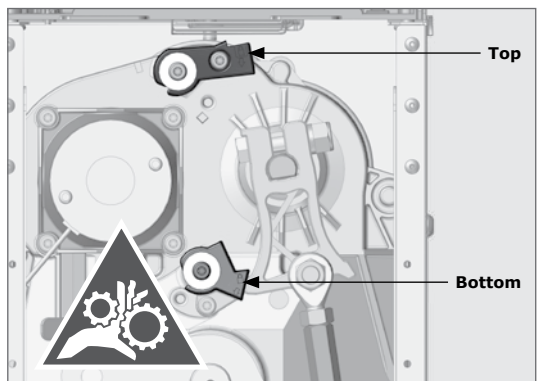


FIGURE 39

### 8.1.2.1 Check the Spring Tension

- Press the down arrow button on the controller while it is in standby mode to check the spring tension
- On the display, it will show how many turns are required and in which direction in order to balance the spring

Refer to "Section 5 - Basic Controller Setup" in this manual, for further information.

### 8.1.2.2 Special maintenance for Grade 316 Stainless steel barriers

Oxidation in marine and coastal areas may result in brown discolouration ('tea staining') of the barrier housing and, while this does not impact the structural integrity of the barrier adversely, it is unattractive and can be easily prevented by regularly washing the barrier-housing with a soft cloth and warm water. A mild detergent may also be used. This will remove salt and other corrosive materials from the housing and retain the attractive sheen of the stainless steel.

### 8.1.3 General checks

- The Pole length must always correspond with the spring and the gearbox of the **SECTOR II**
- The loop wires must always be twisted
- After every **1,75M** operations, it is recommended to get the **SECTOR II** serviced
- Check all cables, ensuring that they are routed correctly and still in good condition, and re-wire if necessary

## 8.2 Site related issues

### 8.2.1 If the boom does not want to complete SETUP

- Remove the motor and check that the spider couplers are not damaged
- Check that the drive arm is not slippery
- Check whether the DOSS is still plugged in properly and no dust has developed on the optic sensors
- Check the drive circuit on the controller by navigating to the relevant diagnostic screen
- With the controller powered up and the screen in standby mode displaying No Limits Set, press the down arrow button until the screen displays Drive, Motor, Fuse. The controller should display three ticks; in the event that one of the blocks displays an error message, the controller is most likely faulty

### 8.2.2 If the pole does not want to raise after SETUP

- Remove the motor and check that the spider couplers are not cracked
- Check that the drive arm is still torqued at 45Nm
- Check the drive clamp

### 8.2.3 Check the spring tension

1. Remove both the charger and the battery from the controller while the pole is in the raised position
2. Manually lower the pole by hand
3. Release the pole; it should reverse and stop at a 45° angle
  - If the pole stays lowered, the spring is too small for the pole or is under-tensioned
  - If the pole raises completely, the spring is too strong for the pole or over-tensioned

## 8.3 Basic adjustments

### 8.3.1 Boom Pole Orientation can be changed onsite

- Refer to "Section 10.2 - Appendix 2. Changing the SECTOR II to a left-hand configuration" of this installation manual for detailed information

### 8.3.2 Leveling the boom pole

- Use the level adjustment link together with a spirit level to level the boom pole

### 8.3.3 The endstops can be positively locked

1. Remove the screw in the Top and/or Bottom Locking Stops.
2. Swing the Locking Stop to the required position.
3. Navigate the controller to menu 5.1 to activate the setting.
4. Replace the screw in the Top and/or Bottom Locking Stops.

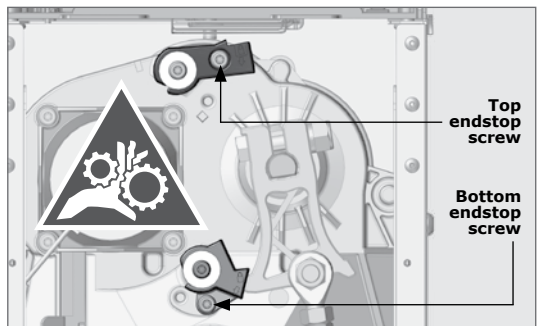


FIGURE 40

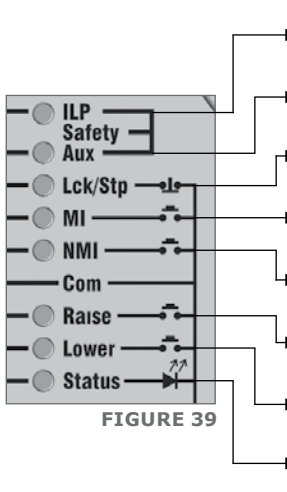
## 9. Troubleshooting

### 9.1. Diagnostics

The following diagnostics enable analysis of why the unit is not performing as expected.

#### Diagnostic LEDs

The **S-SERIES** controller has a series of diagnostic LEDs which indicate the state of the inputs. Normally-open inputs are indicated by a red LED, and normally-closed inputs by a green LED. An illuminated red LED indicates that the signal is present (e.g. barrier-raise pressed), while a non-illuminated green LED indicates that the signal is absent (i.e. IRB broken)



<b>ILP</b>	Green	on	When the inductive loop detector output is not activated
<b>Aux input</b>	Green	on	When the Aux input is not activated
<b>Lck/Stp</b>	Green	on	When the Lck/Stp input is not activated
<b>MI</b>	Red	on	When the memory input signal is present
<b>NMI</b>	Red	on	When the non-memory input signal is present
<b>Raise</b>	Red	on	When a Barrier Raise signal is present
<b>Lower</b>	Red	on	When a Barrier Lower signal is present
<b>Status</b>	Red	on	This LED indicates the status of the barrier as per the table below

TABLE 10

#### SECTOR II traffic barrier status LED

Off	Barrier is lowered
On	Barrier is partially or fully raised
Continuous slow flash	Barrier is raising
Continuous fast flash	Barrier is lowering
One flash every two seconds	Pillar-Light override is activated
Two flashes every two seconds	No mains present
Three flashes every two seconds	Battery voltage is low
Four flashes every two seconds	Multiple collisions have occurred

TABLE 11

## LCD display

The **S-SERIES** controller's LCD display shows valuable information regarding the status of the system.

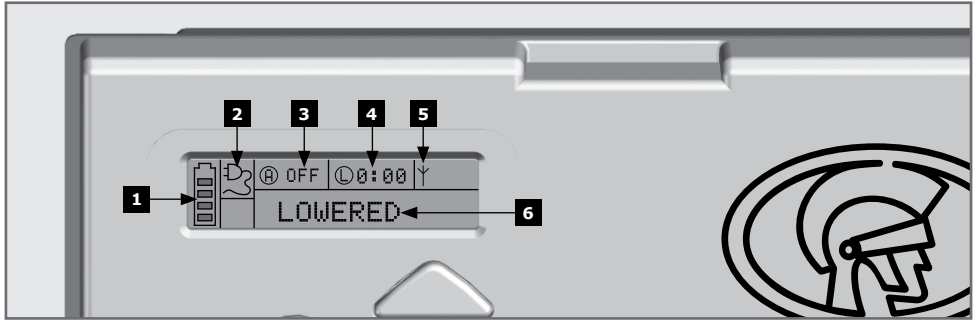


FIGURE 41. S-SERIES CONTROLLER LCD

### 1. Battery icon

Indicates the state of charge of the battery.

- Four solid bars = full capacity
- Two solid bars = 50% capacity
- No solid bars, with the icon flashing = battery empty

### 2. Mains icon

Displays the presence / absence of mains voltage:

- Plug solid = mains present and battery charging
- Plug hollow and flashing = No mains present and battery not charging

### 3. Autolower information

- Displays the state of the Autolower function
- Displays off if Autolower is not selected
- OVR if Autolower is overridden, and the remaining Autolower time if Autolower is active

### 4. Pillar Light/Ticket-Vend-Interlock (TVI) information

- Displays the remaining courtesy light time, if the courtesy-light-mode is selected
- Pre-flashing mode is displayed if pre-flash is selected
- LIT will be indicated if the pillar light has been turned on permanently
- TVI will be indicated if the TVI output has been configured

### 5. Onboard receiver information

- Displays the current input being activated by the onboard receiver

### 6. Status information

- Displays useful information regarding the status of the barrier

## Buzzer feedback

A warning buzzer will sound (where applicable) as per the table below:

Inhibitor name	Priority	Number of beeps	Fault type	Boom continues to operate	User can correct error
Break-in alarm	1	Continuous tone for 30 seconds	Alarm	N/A	N/A
Presence alarm	2	Continuous tone until ILD is cleared	Alarm	N/A	N/A
Battery low	3	3 beeps periodically for 30 seconds	Power system fault	Yes <sup>1</sup>	Yes
Multiple collision	4	Periodic until condition is cleared by user (500/500ms)	Collision	No	Yes
Auxiliary overload	5	5 beeps periodically for 30 seconds	Hardware	No	No
Holiday Lockout	6	1 beep periodically for 30 seconds	User	No	Yes
Emergency stop	7	1 beep periodically for 30 seconds	User	No	Yes
Time-barring	8	1 beep periodically for 5 seconds	User	No	Yes
No limits set	9	3 short beeps for 5 seconds	Lost	No	Yes
Mains failure	10	2 beeps periodically for 30 seconds	Power system fault	Yes	Yes
ILD broken	11	1 beep periodically for 30 seconds	User	No	Yes
DOSS disconnected	12	5 beeps periodically for 30 seconds	Hardware	No	No
Fuse blown	13	5 beeps periodically for 30 seconds	Hardware	No	Yes
Motor disconnected	14	5 beeps periodically for 30 seconds	Hardware	No	Yes
Bridge damaged	15	5 beeps periodically for 30 seconds	Hardware	No	No
Barrier stalled	16	4 beeps periodically for 10 seconds	Collision	No	Yes

1. The boom pole will close fully and then shut down for two minutes

**TABLE 12**

## 10. Appendices

### 10.1. Appendix 1. SECTOR II specifications

#### 10.1.1. Unit specifications

Depending on the site, the user will need to decide on what type of barrier is most suitable. Table 12 shows the specifications of the various units. Please note that the operator type and speed varies based on the chosen pole length.

SECTOR II traffic barrier	3 Metre <sup>8</sup>	4.5 Metre <sup>8</sup>	6 Metre <sup>8</sup>
Input voltage <sup>1</sup>	110 - 240V AC ±10%, 50/60 Hz		
Motor voltage	12V DC		
Motor power supply <sup>2</sup>	Battery-driven (standard capacity - 7 Ah)		
Battery charger	CP84SM – 1.8A @ 13.8V		
Current consumption (Mains)	170mA		
Boom pole length	3.0M	4.5M	6.0M
Boom pole raise time (adjustable) <sup>3</sup>	1.2 Sec	3 Sec	3 Sec
Manual override	6mm Allen key-operated from outside of the unit		
Maximum number of operations per day	3000		
Duty cycle - mains present <sup>4,5</sup>	80%		
<b>Operations in standby with 7Ah battery</b>			
Half day <sup>6</sup>	3000 <sup>7</sup>		
Full day <sup>6</sup>	3000 <sup>7</sup>		
Collision sensing	Electronic		
Operating temperature range	-15°C to 55°C ambient <sup>9,10</sup>		
Receiver code storage capacity	500 Transmitter buttons		
Receiver frequency	433.92 MHz		

**TABLE 13**

- Can operate off a solar supply, consult Centurion Systems (Pty) Ltd for assistance.
- Battery capacity can be increased for longer standby times (Battery capacity </=33Ah unless charger is upgraded).
- Boom-pole raise and lower-times are both individually configurable to suit individual installation requirements.
- Based on 25°C ambient temperature and unit not in direct sunlight.
- Based on an output torque of less than 50% of rated torque.
- Based on basic operator excluding closing-loop detector.
- Limited by daily usage.
- The model designation of the barrier is an indication of the maximum length of pole for the specific spring. In other words, **SECTOR II** 3m = maximum 3m pole; **SECTOR II** 4.5m = maximum 4.5m pole, etc. In other words, if you wish to fit a 4.5m pole, a **SECTOR II** 4.5m/6m with corresponding spring must be used.
- Refer to a battery data sheet for battery operating temperatures.
- For particularly hot areas, the Operator will remain within its operating temperature if the product is installed in a shaded environment.

**10.1.2. Barrier boom pole specifications**

<b>SECTOR II boom pole</b>	<b>3 Metre</b>	<b>4.5 Metre</b>	<b>6 Metre</b>
Material and profile	Aluminium, round profile with plastic end cap		
Dimensions	Outside diameter 76.2mm; wall thickness 1.27mm		
Weight	800 g/m		
Surface Protection, colour and markings	Epoxy-coated white with red reflective tape		
Mass of pole (kg)	2.4 kg	3.7 kg	4.9 kg

**TABLE 14****10.1.3. Fuse protection**

<b>Item</b>	<b>Fuse type</b>	<b>Rating</b>
<b>Main controller</b>		
Motor circuit	Automotive fuse ATO (25x7mm)	30A
Light circuit	5 x 20mm glass fuse	3A Fast blow
Auxiliary supply	Electronic limit	300mA
<b>Charger</b>		
Mains input	5 x 20mm glass fuse	3A Fast blow

**TABLE 15**

**10.1.4. Certificate of compliance**

This page has been left blank intentionally

## 10.2. Appendix 2. Changing the SECTOR II to a left-hand configuration

### 10.2.1. Changing over the internal spring assembly

Follow the steps below to change the barrier orientation as required by the site.

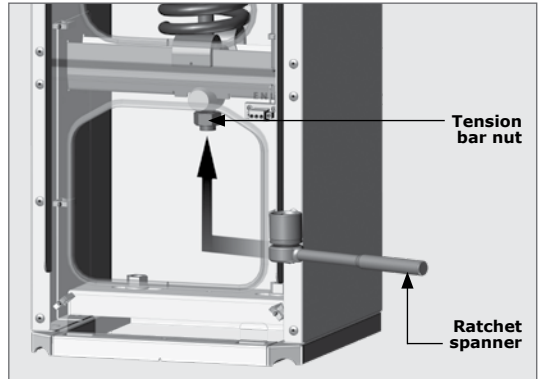


FIGURE 42

### Removing the internal spring assembly

#### Step 1

Place the boom pole in the upright position. Remove the pole by removing the M8 nuts (refer back to Figure 16).

#### Step 2

Use a 24mm socket (4.5 and 6M boom) or a 17mm socket (3M boom) and a ratchet spanner to relax the tension on the spring by unwinding the nut in an anti-clockwise direction. Continue until there is no more tension in the spring whatsoever (Figure 43).

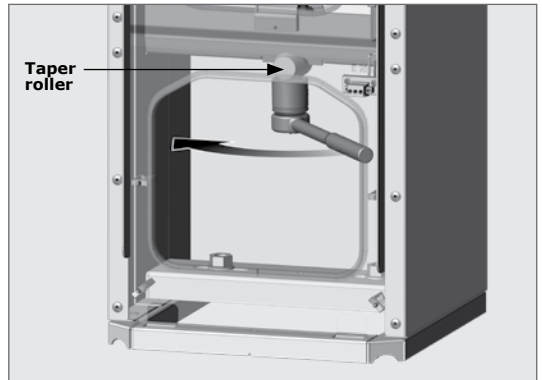


FIGURE 43

#### Step 3

When the spring is completely loose, rotate the taper roller at the bottom of the spring assembly 90° (Figure 44). This will allow you to lift the entire spring assembly out.

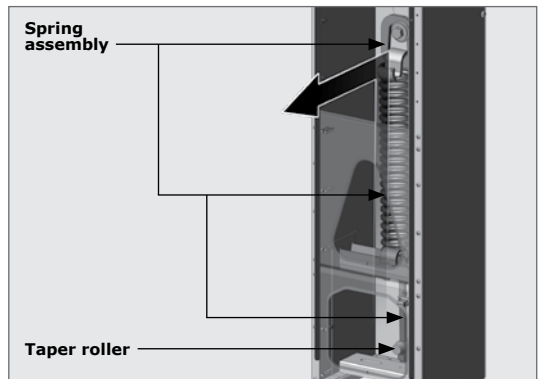


FIGURE 44

## Reconfiguring the output shaft plate

### Step 3

With the spring out of the way, use the 24mm socket and ratchet combination to loosen the spring bolt (Figure 45). This is held in place by a thread-locking adhesive and will require some considerable force to undo.



When unscrewing the spring bolt the output shaft plate will rotate in an anti-clockwise direction before locking into position. From this point it is possible to unscrew the bolt completely.

### Step 4

Move the spring bolt and washers to the left-hand spring bolt position on the output shaft plate. Use Loctite 290 (green thread locker) on the bolt-threads and use a torque wrench to tighten it to 45Nm. (See Figure 46 to see the new bolt position). The unit is now ready for the spring assembly to be re-installed.



Ensure that the spring orientation is correct before inserting the spring back into the cabinet. Figures 48 and 49 depict the correct and incorrect spring orientations.

### Step 5

Insert the spring assembly back into the cabinet (Figure 47), making sure that the orientation is correct according to Figure 49, and that the taper roller slides into the groove of the spring support bracket at the bottom of the cabinet as you hook the spring onto the bolt.

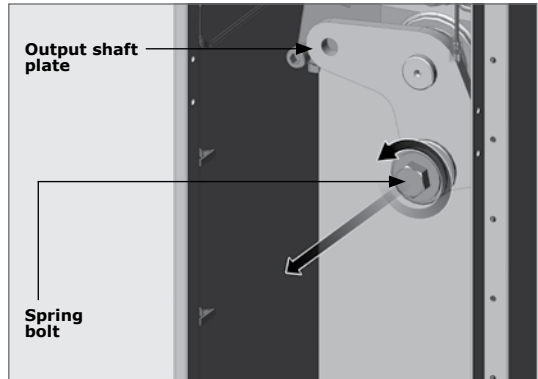


FIGURE 45

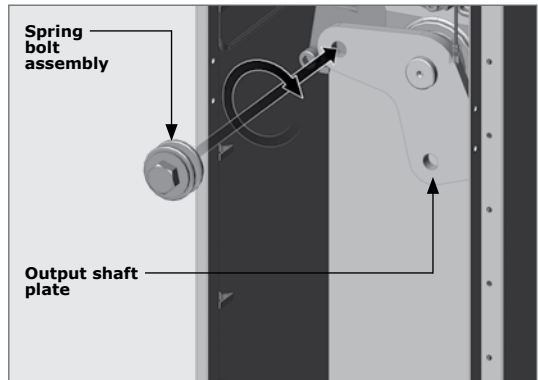


FIGURE 46

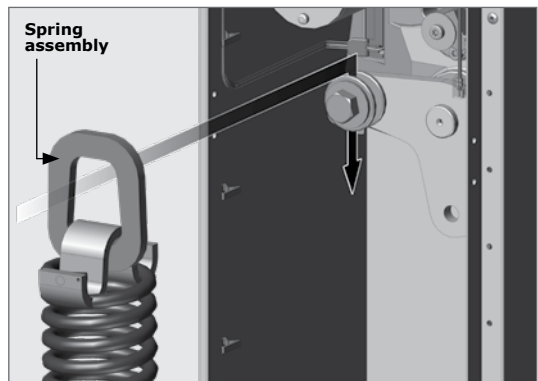


FIGURE 47

## Ensuring the correct spring assembly orientation



The orientation of the top coil of the spring is critical with regards to the operation of the barrier. If it is the wrong way around, the spring will strike the output shaft plate which will impede its operation. See Figures 48 and 49 for the CORRECT spring orientation!

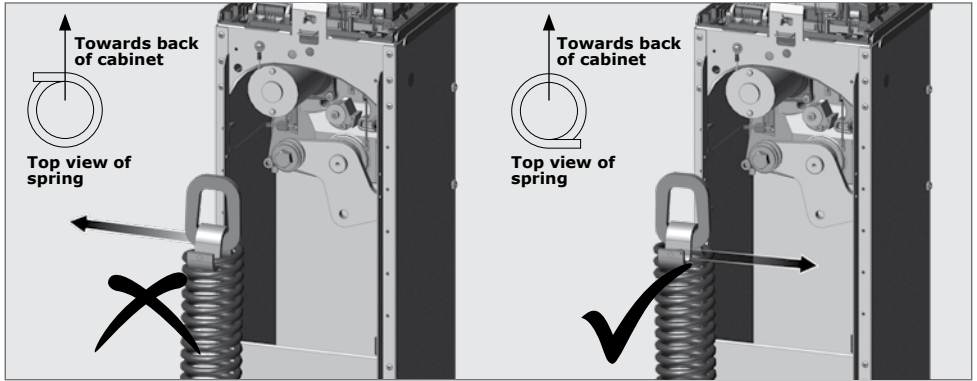


FIGURE 48. SPRING ORIENTATION OF A LEFT-HAND SECTOR II TRAFFIC BARRIER

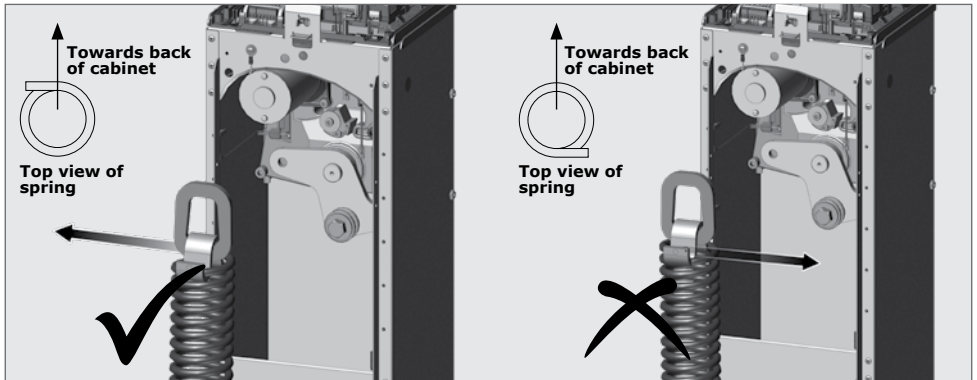


FIGURE 49. SPRING ORIENTATION OF A RIGHT-HAND SECTOR II TRAFFIC BARRIER



Remember to tighten the spring (but not fully) using the spring tension nut to avoid the spring falling out of position.

## Removal and re-orientation of the boom pole coupler

Once the internal spring assembly has been reconfigured, the orientation of the boom pole coupler needs to change.

Follow the steps below to obtain the correct orientation:

### Step 1

Remove the M10 cap screw using an 8mm Allen key (not supplied) and washer from the inside of the coupler (Figure 50).

### Step 2

Attempt to gently tap the coupler off. If this is not possible, then a coupler-puller may be required to remove the boom pole coupler if the taper lock has locked in tightly on the coupler.

The coupler-puller can be purchased from Centurion Systems (Pty) Ltd, or a similar one can be fabricated as shown in Figure 51.



If the coupler has been successfully removed without the need of the coupler puller, skip to Step 7.

### Step 3

If using the coupler-puller kit, replace the original cap screw with the black M10x35 cap screw supplied in the coupler-puller kit.

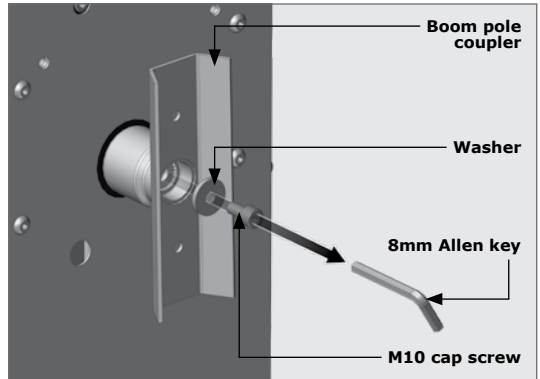


FIGURE 50

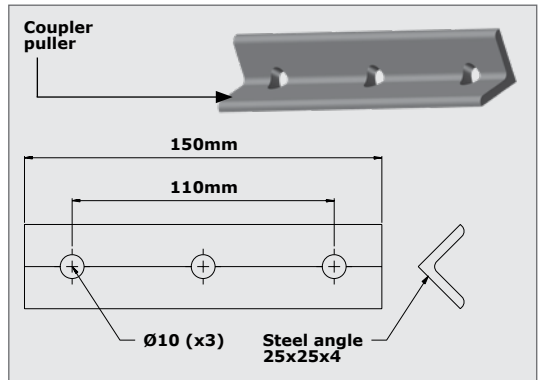


FIGURE 51

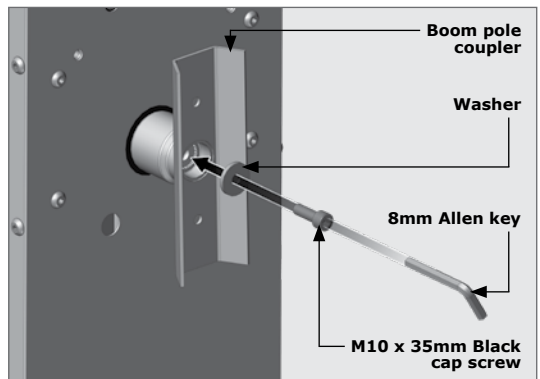


FIGURE 52

**Step 4**

Fit the coupler-puller to the boom pole coupler with the two M8 bolts and nuts provided in the coupler-puller kit (Figure 53).

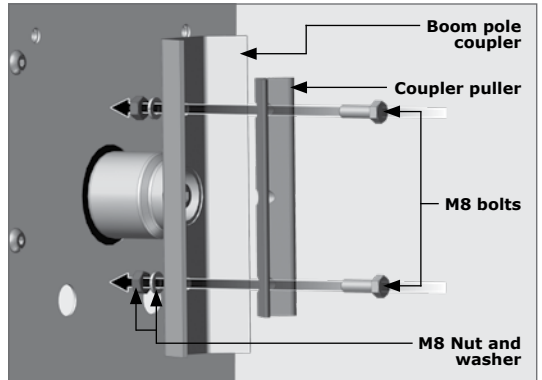


FIGURE 53

**Step 5**

Using an Allen key, unscrew the cap screw fitted in the middle of the shaft, which is reached through the middle hole in the coupler-puller. As the cap screw comes out it will push against the coupler-puller and pull the coupling off of the output shaft.

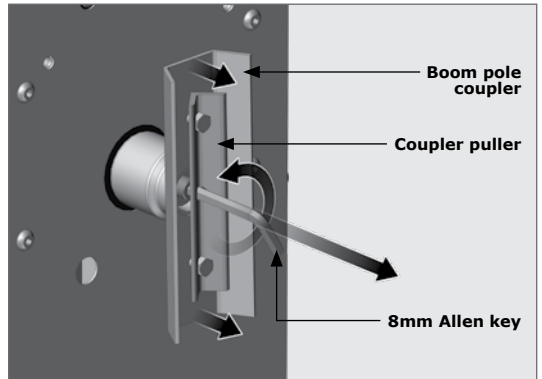


FIGURE 54

**Step 6**

Remove the coupler-puller components from the coupler.

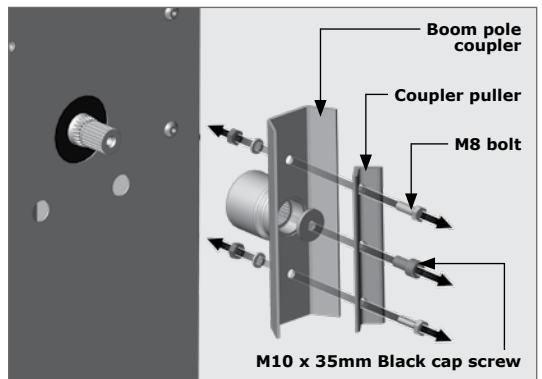


FIGURE 55

**Step 7**

Refit the coupler so that the pole will be vertical when the drive arm is at the top (Figure 56). If the drive arm is not at the top when the pole is in the vertical position, move the drive arm to this position by hand. The splines of the shaft will need to be aligned as precisely as possible, even though there is some adjustment provided for it in the linkage (Section 3.3).

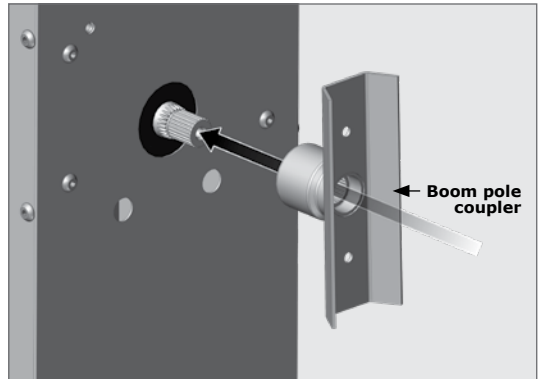


FIGURE 56

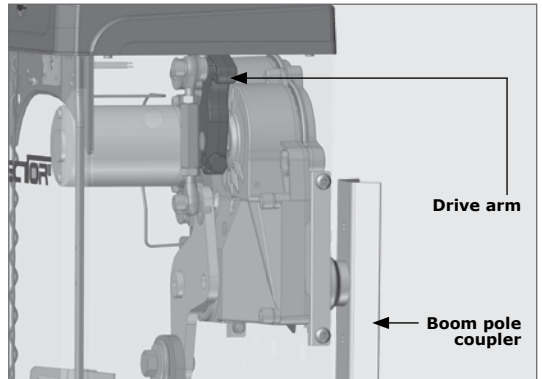


FIGURE 57

**Step 8**

Replace the washer and original cap screw in the centre of the shaft.

**Step 9**

Tighten the cap screw with the Allen key until the coupler is fastened tightly in position.

Continue with the installation as per 'Section 3.3. Fitting and levelling the boom pole'.

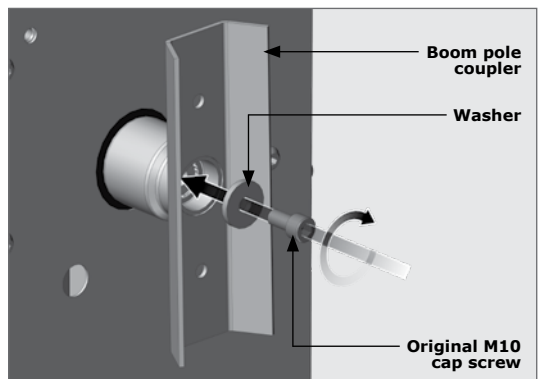


FIGURE 58

### 10.3. Appendix 3. Adjusting limits for Fail-safe Mode

The standard **SECTOR II** is supplied in Fail-safe Mode, meaning that the boom can be moved from the raised or lowered positions without requiring a manual override.

Alternatively, the operator can be configured so that, when mains power is present, the boom pole cannot be lifted or forced down but, in the event of a power-failure, the pole can be operated by hand. This can be set in the menu system (Menu 5.1).

In certain circumstances when the **SECTOR II** needs to be in 'Locked Mode', (meaning that the boom pole cannot be raised, or lowered, by hand), it will require use of the 6mm Allen key (provided) in the manual override slot to raise, or lower, the boom pole.

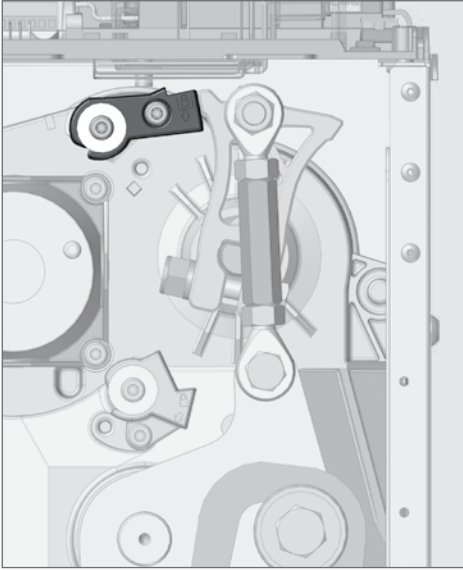


**Ensure all power to the SECTOR II is OFF by switching off both the AC and DC isolator switches.**

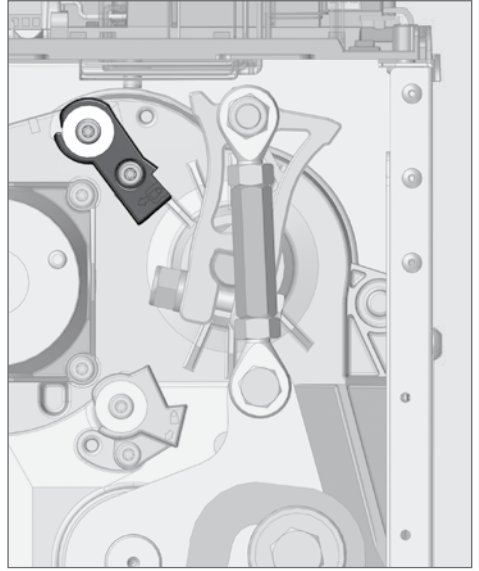
To convert the locking stops from Fail-safe Mode to Lock Mode, the stopper screw needs to be unscrewed using a T30 TORX extended length bit, a 1/4" ratchet spanner and appropriate ratchet adaptor. Rotate the locking stop to the locked position, insert the screw and tighten using the aforementioned tools.

The following figures show the endstops in their locked and unlocked (fail-safe) positions respectively.

**Top limit**

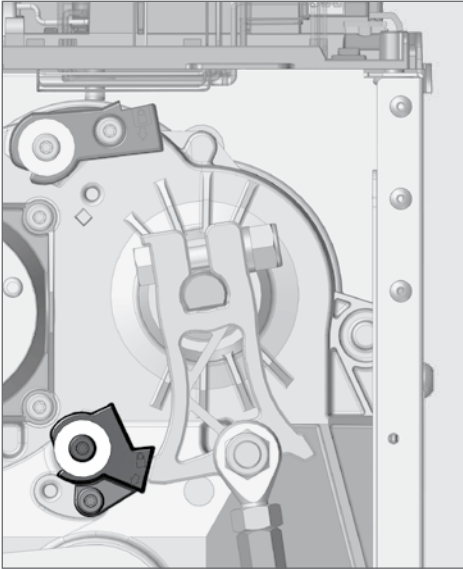


**FIGURE 59. TOP LIMIT ENDSTOP IN THE STANDARD (FAIL-SAFE) POSITION**

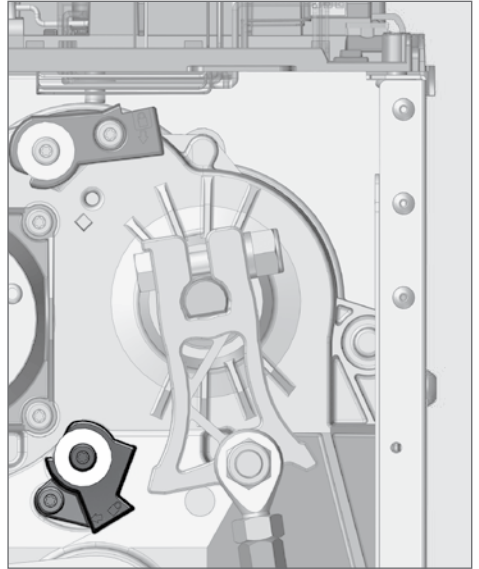


**FIGURE 60. TOP LIMIT ENDSTOP MOVED DOWN (LOCKED POSITION AT TOP)**

**Bottom limit**



**FIGURE 61. BOTTOM LIMIT ENDSTOP IN THE STANDARD (FAIL-SAFE) POSITION**



**FIGURE 62. BOTTOM LIMIT ENDSTOP MOVED DOWN (LOCKED POSITION AT TOP)**

### Fail-safe/Lock Mode

When the barrier is in Fail-safe Mode, the boom pole can be manually moved by hand.

In Lock Mode, the boom pole is locked in the raised or lowered position and cannot be moved by hand.

These configurations are implemented by setting the top and bottom locking stops on the gearbox in different positions. (indicated in Figure 63)

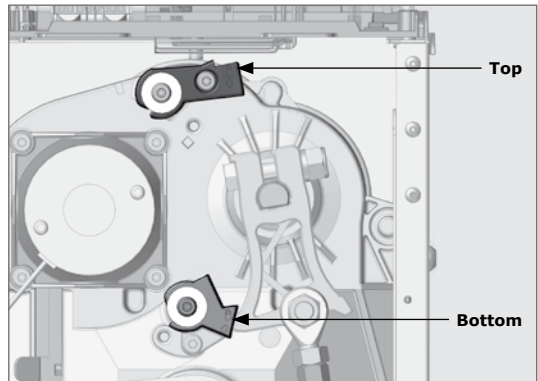


FIGURE 63

- For a right-hand boom to be placed in Lock Mode in the lowered position, position the top stopper as shown in Figure 64 (similarly for the left-hand raised locked position)

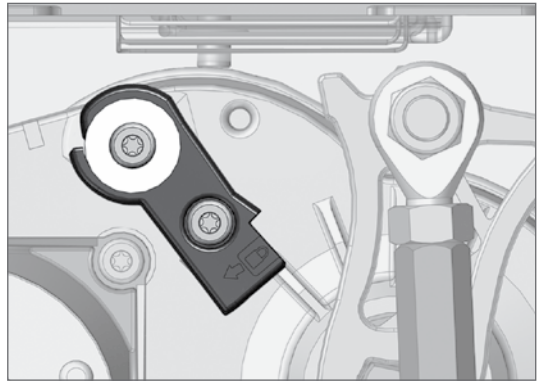


FIGURE 64. LOCK MODE POSITION (TOP)

- For a right-hand boom to be placed in Lock Mode in the raised position, position the top stopper as shown in Figure 65 (similarly for the left-hand lowered locked position)

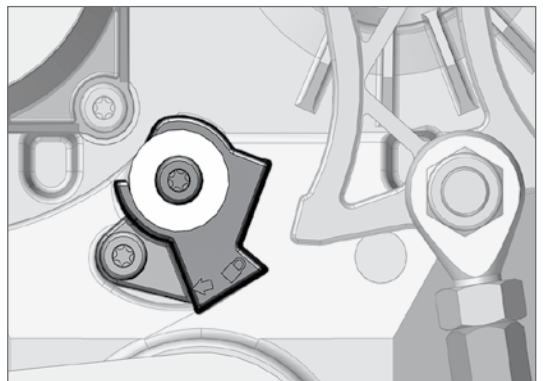


FIGURE 65. LOCK MODE POSITION (BOTTOM)

## 10.4. Appendix 4. FLUX 11-Pin loop detector installation

### 10.4.1 Single 11-pin loop detector

The **SECTOR II** is suited for use with different loop detector types, including 11-pin loop detector modules. The 11-pin base unit screws down through the tray, into the chassis.

#### Step 1

Screw the 11-pin base onto the electronics tray (Figure 67 and 68).

#### Step 2

Run the TWISTED loop wires up the inside of the enclosure through the wiring clips to the FLUX 11-pin unit.

#### Step 3

Wire the loop wires into the FLUX 11-pin unit.

#### Step 4

Wire the FLUX 11-pin into the **S-SERIES** controller using the supplied loop wire harness, following the wiring diagram shown in Figure 69.

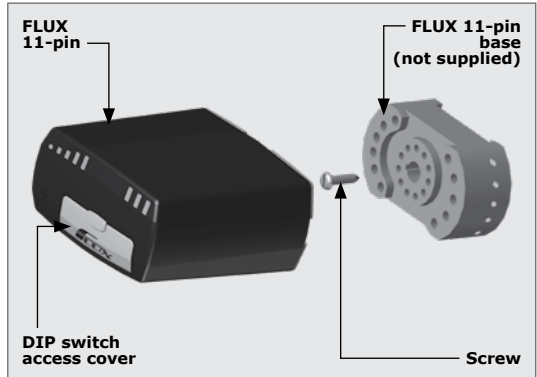


FIGURE 66

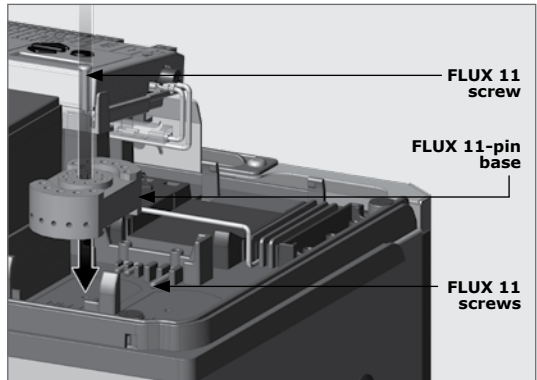


FIGURE 67

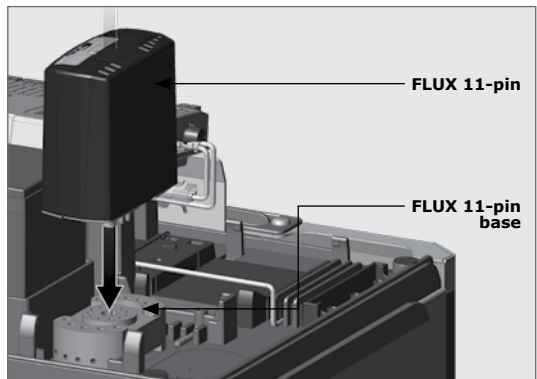


FIGURE 68



This wiring diagram assumes that a CENTURION FLUX loop detector is being used. If another brand of loop detector is being used, please refer to the documentation that accompanied the detector as there might be differences in how it should be connected.

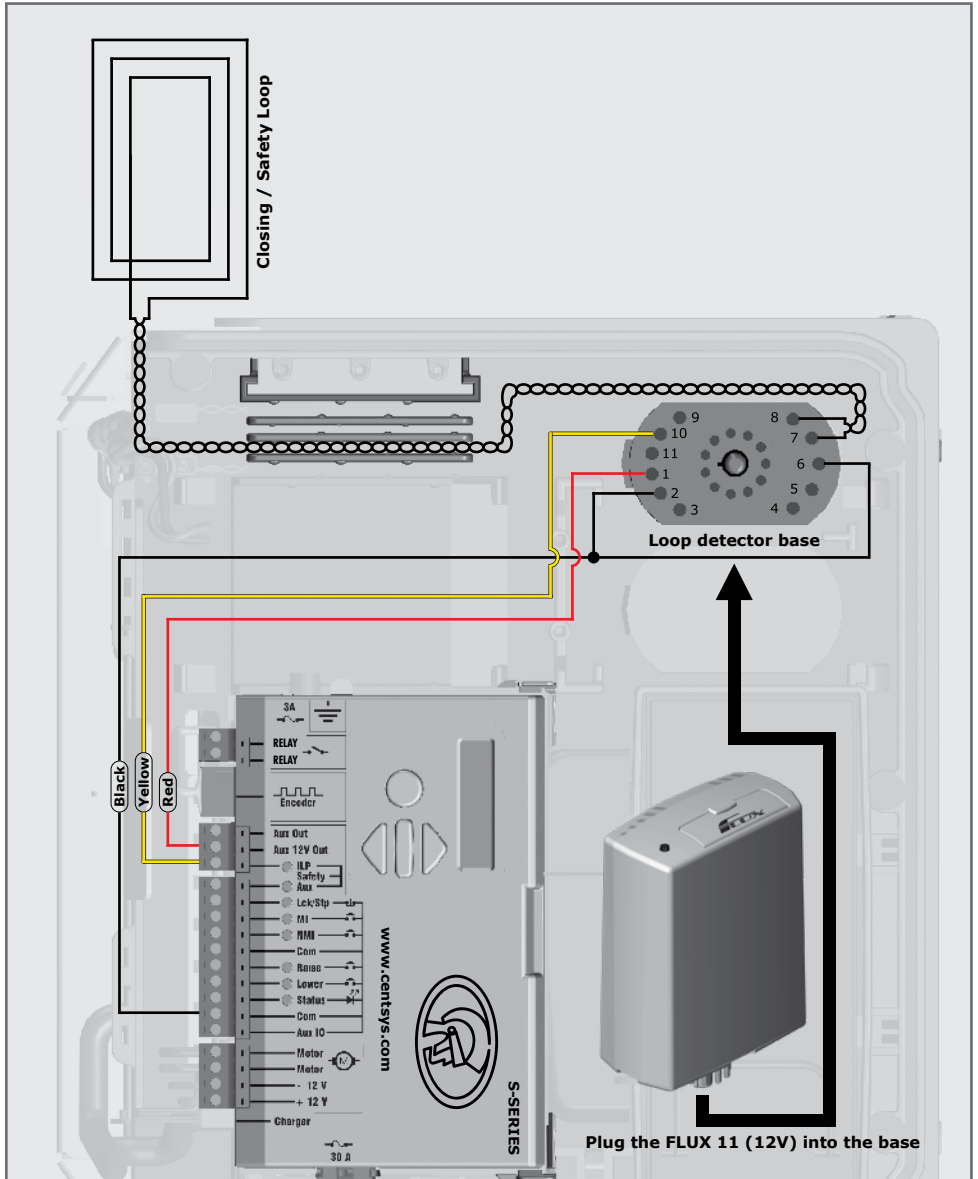


FIGURE 69. WIRING THE FLUX 11-PIN AS A CLOSING / SAFETY LOOP

If only one FLUX 11-pin loop detector is required for the installation, continue with the installation as per 'Section 5 - Basic controller setup'.

Should a second FLUX 11-pin loop detector be required, continue to the next step.

## DIP switch settings:

For the settings and descriptions, see the pocket-guide provided with the FLUX 11-pin.

### 10.4.2 Dual 11-pin loop detector

In some operating modes, a barrier may require two FLUX 11-pin loop detectors. A typical application for a double loop system is where both a safety and a free-exit loop is required. The following steps detail the process:

#### Step 1

Having already installed the first 11-pin loop detector, screw the second 11-pin base onto the electronics tray (Figure 71 and 72).

#### Step 2

Run the TWISTED loop wires up the inside of the enclosure through the wiring clips to the second FLUX 11-pin unit. Take note of the channels provided to separate each of the twisted pairs for the relevant loop detector (Figure 71).

#### Step 3

Wire the loop wires into the second FLUX 11-pin unit.

#### Step 4

Wire the second FLUX 11-pin into the **S-SERIES** controller using the supplied loop wire harness, following the wiring diagram shown in Figure 73.

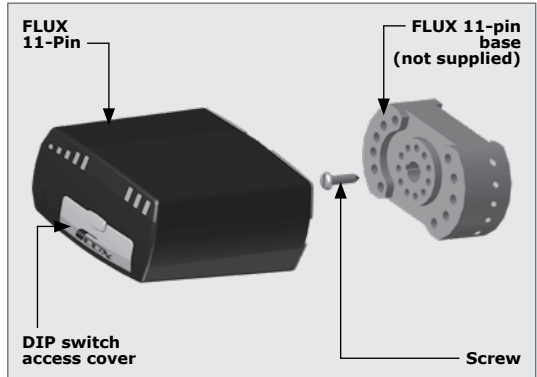


FIGURE 70

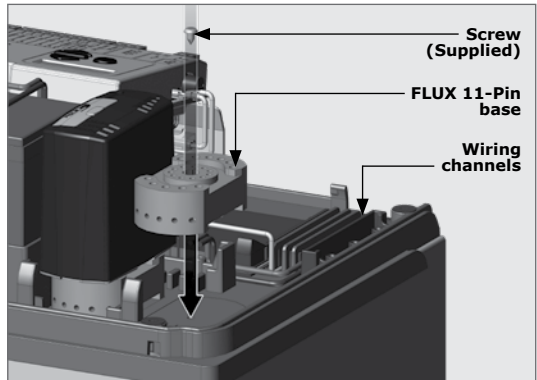


FIGURE 71

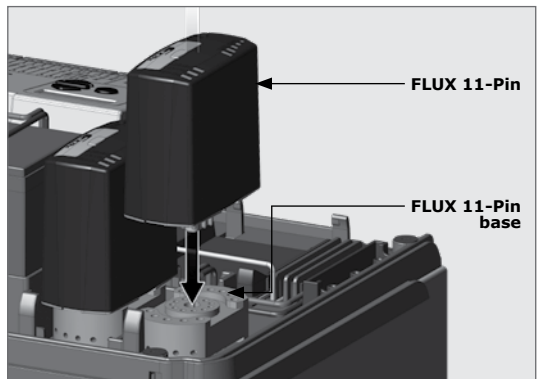


FIGURE 72



This wiring diagram assumes that a CENTURION FLUX loop detector is being used. If another brand of loop detector is being used, please refer to the documentation that accompanied the detector as there might be differences in how it should be connected.

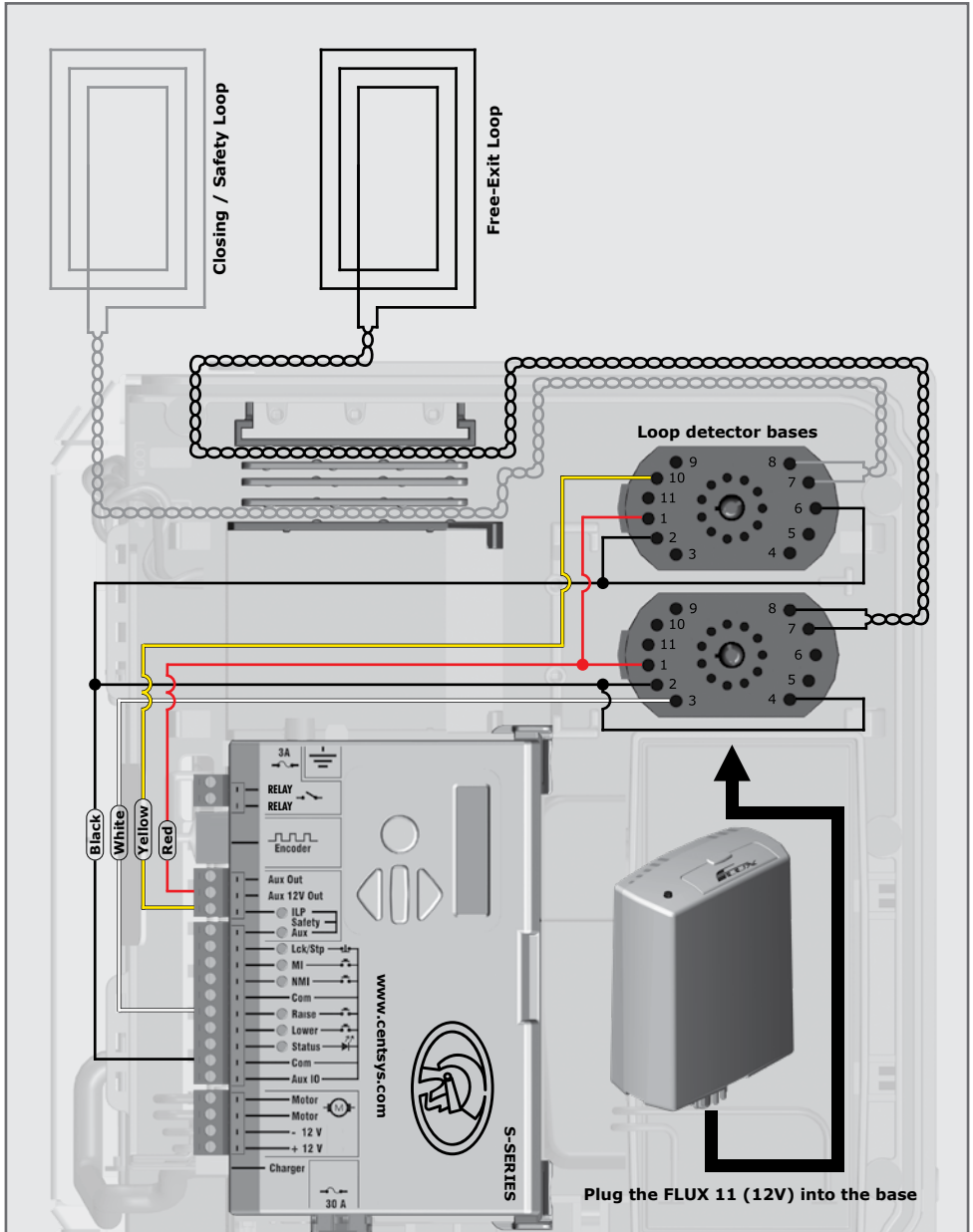


FIGURE 73. WIRING THE FLUX 11 WITH A DUAL LOOP CONFIGURATION

Continue with the installation as per 'Section 5 - Basic controller setup'.

### 10.5. Appendix 5. Safety beam installation

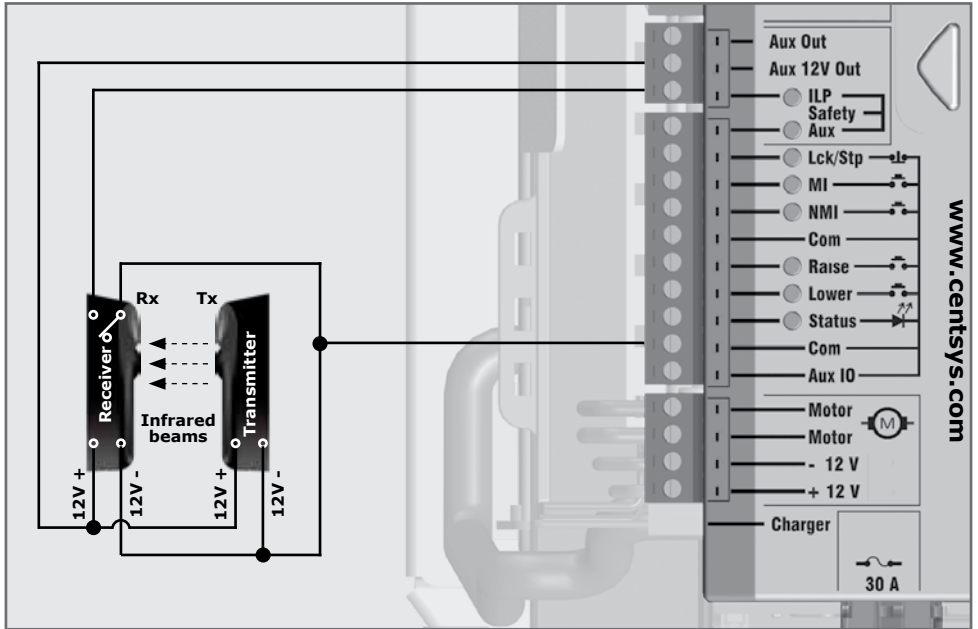


FIGURE 74. SECTOR II - 15 IR BEAMS SHOWN

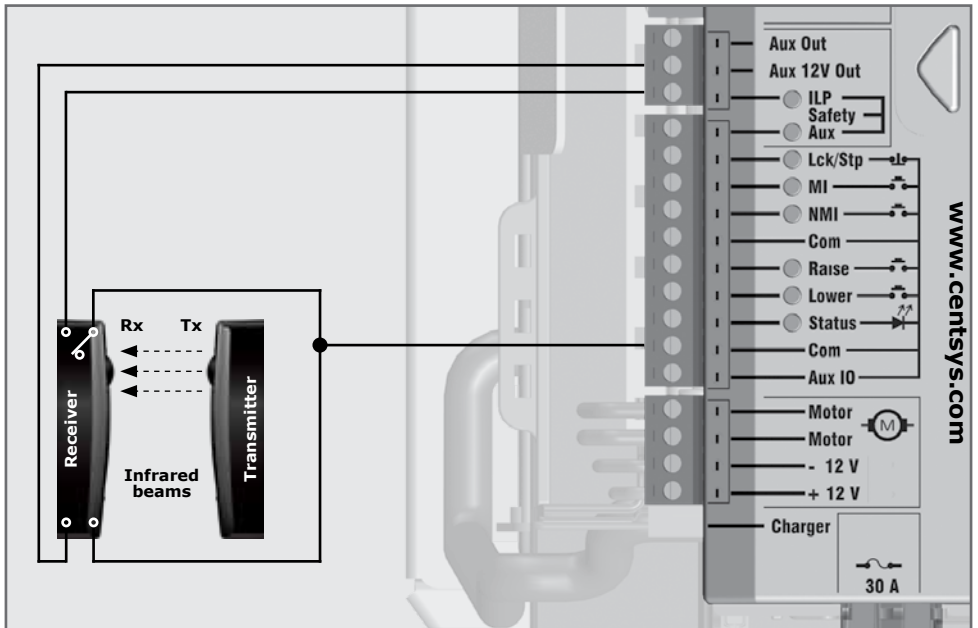


FIGURE 75. SECTOR II - PHOTON IR BEAMS SHOWN

## 10.6. Appendix 6. Wiring diagrams for installation modes

### 10.6.1. Simplex Mode

These modes relate directly to the installation modes shown in Menu 4.

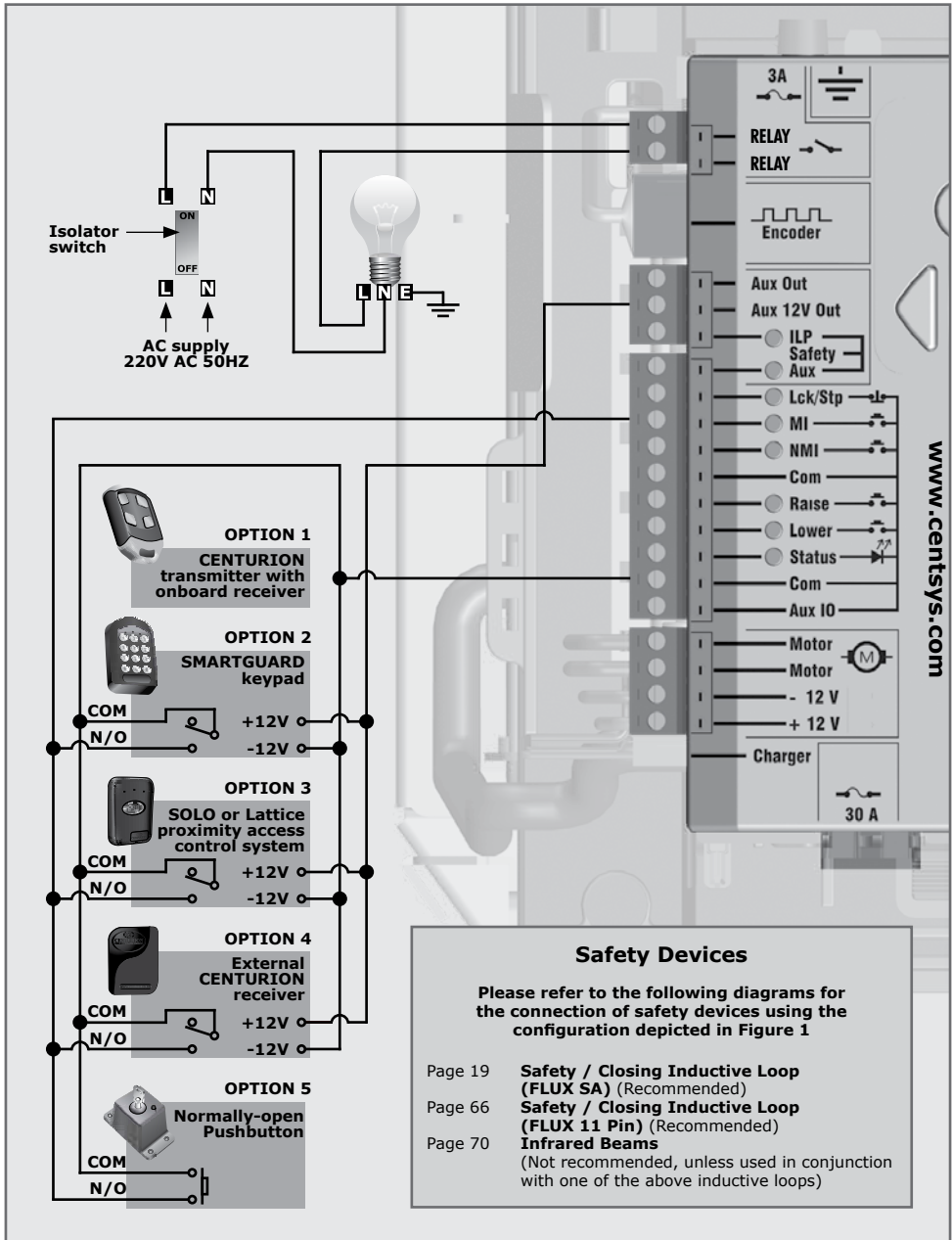


FIGURE 76. SECTOR II - SIMPLEX MODE

10.6.2. Complex Mode (Option 1)

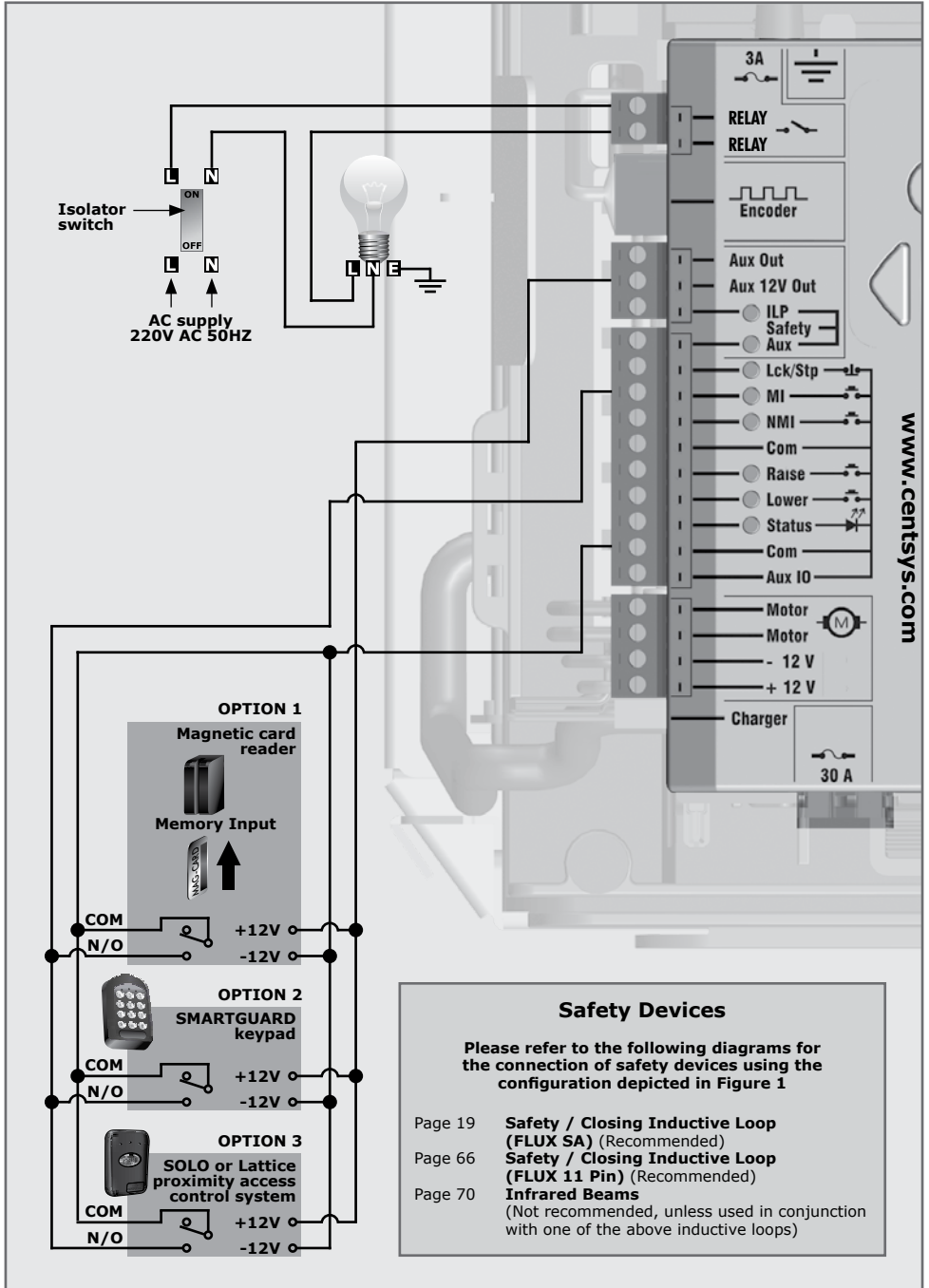


FIGURE 77. SECTOR II - COMPLEX MODE (OPTION 1)

## 10.6.3. Complex Mode (Option 2 - Ticket vendors)

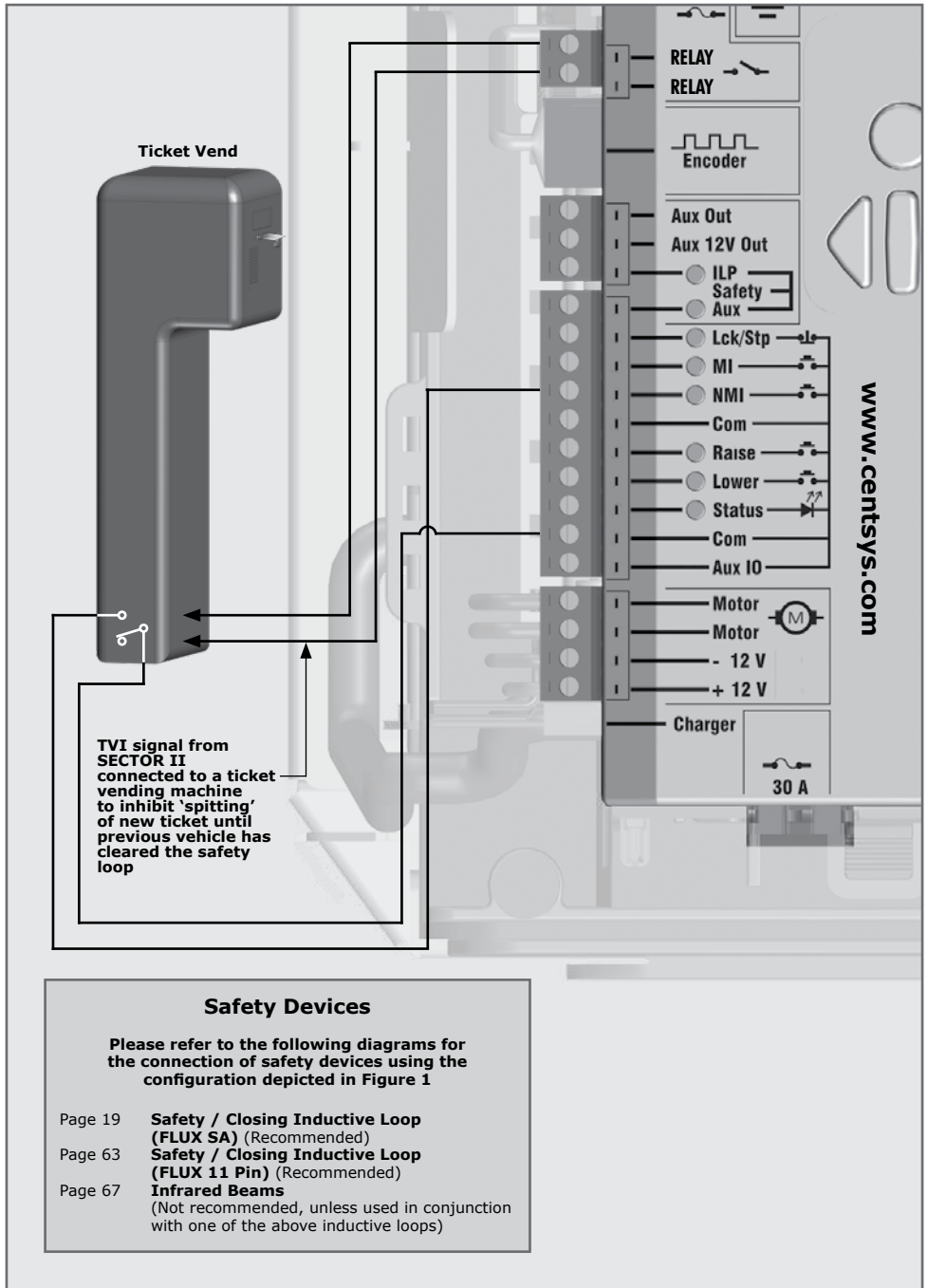


FIGURE 78. SECTOR II - TICKET VENDORS

#### **10.6.4. Uni-directional traffic**

The free-exit function allows vehicles to exit a facility by automatically raising the barrier. It is recommended that an inductive loop detector be used to activate the free-exit facility. Infrared beams can be used for this function but a loop detector is preferred.

The free-exit loop will raise the barrier and the closing loop will be used to lower the barrier the moment the vehicle has exited. Select the relevant direction on the control card within the loop detector menu, refer to Section 7.

#### **10.6.5. Bi-directional traffic**

This allows access for traffic from both directions in a single lane. In this case the same barrier provides access control for vehicles entering and free-exit for vehicles exiting. A triggering device can be used for the access function and the loop for the free-exit function.

The free-exit loop must be mounted close enough to the closing loop so that the vehicle exiting is still present on this loop when it reaches the closing loop. However, these must not be too close together (a distance greater than 1000mm is required), or magnetic interference will be caused.

The free-exit loop will raise the barrier and the closing loop will be used to lower the barrier the moment the vehicle has exited. Select the relevant direction on the control card within the Loop Detector Menu refer to Section 7.

## 10.7. Appendix 7. Factory default settings

### South African standard profile – ZA

Parameter description	Unit	Minimum	Default	Maximum
<b>Menu 1 - not applicable</b>				
<b>Menu 2</b>				
Raising collision force	Level	1	3	Max
Lowering collision force	Level	1	3	Max
Collision count	Collisions	1	4	255
Alarm output	B, T, A, X, L <sup>1</sup>		Buzz	
LCK as ESTOP	Yes or No		No	
<b>Menu 3</b>				
Autolower status	On/Off		Off	
Autolower time	Mm:ss	00:00	00:30	4:00
Autolower override time	Mm:ss	00:00	00:01	00:15
Autolower on raised	On/Off		On	
Autolower on partly raised	On/Off		On	
Autolower on partly lowered	On/Off		Off	
<b>Menu 4</b>				
Modes of Operation	S, C, P, SP		CMX	
<b>Menu 5</b>				
Lock when raised	Yes/No		No	
Lock when lowered	Yes/No		No	
Holding force	%	10%	50%	100%
Raise when mains fail	On/Off		On	
Pre-raising delay time	Mm:ss	00:00	00:00	01:05
Pre-lowering delay time	Mm:ss	00:00	00:00	01:05
Raising speed	Deg/sec	10 deg/sec	37 deg/sec	Max
Lowering speed	Deg/sec	10 deg/sec	37 deg/sec	Max
Ramp-up distance	Deg	3 deg	7 deg	15 deg
Ramp-down distance	Deg	3 deg	7 deg	15 deg
TRG stop distance	Deg	5 deg	10 deg	30 deg
Loop stop distance	Deg	5 deg	10 deg	30 deg
Crawl distance	Deg	1 deg	1 deg	5 deg
Torque limit	A	5A	15A	15A

Parameter description	Unit	Minimum	Default	Maximum
<b>Menu 6</b>				
ILAC control	On/Off		Off	
Rollback time	Mm:ss	00:01	00:10	00:15
FRX loop direction	Uni/bi		Uni	
Presence alarm status	On/Off		Off	
Presence time	Mm:ss	01:00	01:00	04:00
Break-in alarm	On/Off		Off	
Alarm output	L, X, A, T, B		LED	
<b>Menu 7</b>				
TVI output function	TVI or CUR		TVI	
TVI output polarity	N/O or N/C		N/C	
Light timer	Hh:mm:ss	00:02:00	00:02:00	09:59:59
<b>Menu 8 – Not applicable</b>				
<b>Menu 9</b>				
Diagnostic screen status	On/Off		Off	
Round test button	On/Off		On	
<b>Menu 10</b>				
Delete not present	On/Off		Off	
Autolearn	On/Off		Off	
Tx menu lock	On/Off		Off	
Onboard receiver	On/Off		On	

TABLE 16

## 10.8. Appendix 8. Terminal descriptions

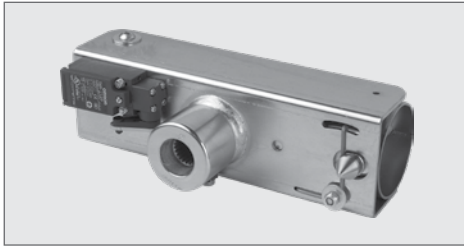
<b>12V +</b>	<b>Positive battery connection.</b> Tip: Battery terminal normally indicated as + or red terminal
<b>12V -</b>	<b>Negative battery connection.</b> Tip: Battery terminal normally indicated as - or black terminal
<b>Motor</b>	<b>Motor output</b> – connects to the <b>thick blue</b> motor wire
<b>Motor</b>	<b>Motor output</b> – connects to the <b>thick black</b> motor wire
<b>Aux IO</b>	The <b>Aux IO</b> terminal provides an open collector output which can be used for alarm or auto-function purposes. If the collision alarm output or the Presence Alarm output has been configured to <b>Aux IO</b> , then the negative of the alarm device must be connected to this terminal. The positive of the alarm device must be connected to the Aux 12V Out terminal. Similarly, if <b>Aux IO</b> is auto-activated via a ChronoGuard auto-activation Time-period, the device being switched (typically a 12V relay) must be powered from the Aux 12V Out terminal, and have its negative switched by <b>Aux IO</b> . If the <b>Aux IO</b> has not been selected as either an alarm-indicator output or auto-activated output, the <b>Aux IO</b> terminal will behave as a 'Com' (i.e. battery negative) termination point. All trigger signals, etc., have their return path to one of the Com terminals

<b>Com</b>	<b>The common termination point.</b> All trigger signals, etc., have their return path to one of the Com terminals
<b>Status</b>	<b>External boom status indication.</b> (A low-current output signal). An output terminal which provides a low-current drive (approximately 4,5V DC, 20mA) to a LED which can be used to indicate the boom status remotely. If more than three LEDs are required, it is necessary to fit the CP78 multi-LED driver card
<b>Aux</b>	<b>The lowering input.</b> (A normally-open potential-free input). Momentarily connecting this input to Com will cause the boom-pole to immediately lower regardless of which position it is in, unless it is already fully lowered
<b>FRX</b>	<b>The raising input.</b> (A normally-open potential-free input). Momentarily connecting this input to Com will cause the boom pole to immediately raise regardless of which position it is in, unless it is already fully raised
<b>Com</b>	<b>A second common termination point.</b> All trigger signals, etc.; have their return path to one of the Com terminals
<b>NMI</b>	<b>The non-memory input.</b> (A normally-open potential-free input). Momentarily connecting (e.g. using a normally-open pushbutton or the Common and NO (normally-open) of a relay contact) the NMI to Com will cause the boom pole to raise, stop or lower depending on the operating mode selected
<b>MI</b>	<b>The memory input.</b> (A normally-open potential-free input). The memory input counts and stores each trigger impulse. The boom pole will stay raised until the same number of closing signals is applied to the closing input, such as the closing loop. This input is typically used in conjunction with the Complex (CMX) Mode of Operation
<b>LCK/STP</b>	<b>Holiday lockout or boom stop input.</b> (A normally-closed potential-free input). For as long as a connection between this input and Com is maintained the controller will behave normally, but when the connection to Com is broken all inputs are inhibited
<b>ILP</b>	<b>The inductive loop detector input.</b> (A normally-closed potential-free input). As long as a connection between this input and Com is maintained the controller will behave normally. When this connection is broken, i.e. a vehicle drives onto the inductive ground loop, it will prevent the barrier from lowering if it is stationary, and will stop and raise the barrier if it is lowering
<b>Aux 12V Out</b>	<b>Auxiliary power connection.</b> Provides +12V DC supply for auxiliary equipment such as a radio receiver, photo cells, etc. It is electronically limited to 300mA
<b>RELAY/RELAY</b>	<b>Ticket vending interlock.</b> These two terminals provide a normally-open potential-free contact which is generally used to introduce an electronic "lock" to ticket vending devices, meaning that tickets cannot be dispensed while the boom pole is raised or raising. Alternatively, the terminals can be used to connect a courtesy or security light which will illuminate whenever the barrier is operated. Com will cause the boom pole to raise, stop or lower depending on the operating mode selected. Each trigger impulse received will cause the barrier to react accordingly

TABLE 17

## 10.9. Appendix 9. Ancillary installation equipment

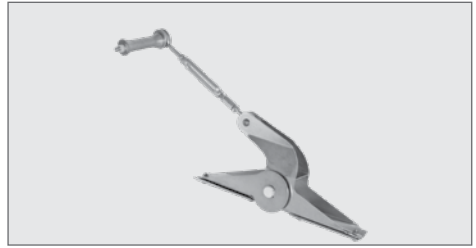
A number of additional devices are available which can be interfaced with the **SECTOR II** traffic barrier to increase security or otherwise enhance the installation.



**FIGURE 79. BREAKAWAY COUPLING**

**Description:**

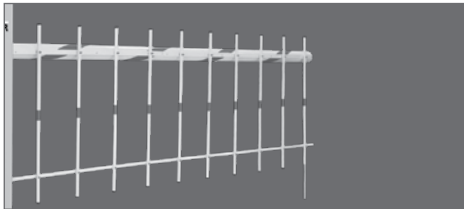
Pole hinges away from barrier if accidentally knocked, reducing the chance of damage.



**FIGURE 80. JACK-KNIFE ASSEMBLY**

**Description:**

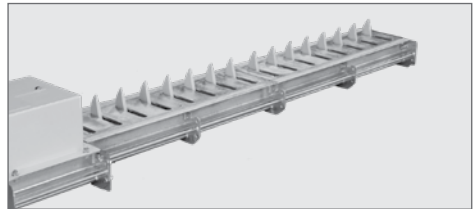
Used in cases where there are height restrictions such as undercover parking



**FIGURE 81. TRAPEZ**

**Description:**

Stops pedestrians from circumventing the **SECTOR II**. Available for 3m and 4.5m boom poles.



**FIGURE 82. CLAWS - FLUSH MOUNT**

**Description:**

Add real security with seamless integration with the **SECTOR II**. Available in 1m and 1.5m sections.



**FIGURE 83. CLAWS - SURFACE MOUNT**

**Description:**

Add real security with seamless integration with the **SECTOR II**. Available in 1m and 1.5m sections.



**FIGURE 84. FLUX 11-PIN**

**Description:**

Required to enable the free-exit or the closing / safety loop facilities



FIGURE 85. FLUX SA

**Description:**

Required to enable the free-exit or the closing / safety loop facilities



FIGURE 86. MIDI TRAFFIC LIGHT

**Description:**

Visually indicates when it is safe for a vehicle to proceed into or out of an access controlled area

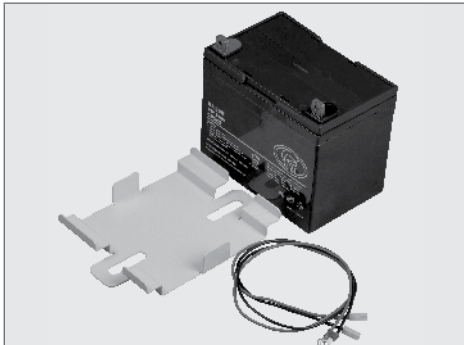


FIGURE 87. 33AH BATTERY KIT

**Description:**

A 33Ah battery can supplement or replace the 7Ah battery for extended battery back-up. Requires a bracket and harness to connect the 33Ah battery to the existing harness.

**Other Ancillaries:**

- Keypad
- SOLO
- Lattice
- G-SWITCH-22
- SMARTGUARDair
- G-SPEAK
- SupaHelix
- NOVA Remote
- NOVA Receiver



Ancillary product documentation is available for download at [www.centsys.com](http://www.centsys.com)



Connect with us on:

 [facebook.com/centurionsystems](https://facebook.com/centurionsystems)

 [YouTube.com/centurionsystems](https://YouTube.com/centurionsystems)

 [@askcenturion](https://twitter.com/askcenturion)

 [centurion.systems](https://centurion.systems)

Subscribe to the newsletter: [www.centsys.com/subscribe](http://www.centsys.com/subscribe)

Call Centurion Systems (Pty) Ltd • South Africa  
Head Office: +27 11 699 2400

Call Technical Support: +27 11 699 2481  
Monday to Friday: from 08h00 to 17h00 (GMT+2)  
Saturday: from 08h00 to 14h00 (GMT+2)

[www.centsys.com.au](http://www.centsys.com.au)

Call: 1300 CENTSYS (1300 236 879)

After Hours International Technical Support Call Centre  
**+27 11 699 2481 (16:00 to 02:00 - Australian Eastern Time)**

**E&OE Centurion Systems (Pty) Ltd reserves the right to change any product without prior notice**  
All product and brand names in this document that are accompanied by the ® symbol are registered trademarks  
in South Africa and/or other countries, in favour of Centurion Systems (Pty) Ltd, South Africa.

The CENTURION and CENTSYS logos, all product and brand names in this document that are accompanied by the TM symbol  
are trademarks of Centurion Systems (Pty) Ltd, in South Africa and other territories; all rights are reserved.  
We invite you to contact us for further details.



Doc number: 1246.D.01.0001\_14062023  
SAP code: DOC1246D01

[www.centsys.com](http://www.centsys.com)